

1. Resistors

Contents

1 Resistor	1
1.1 Electronic symbols and notation	1
1.2 Theory of operation	1
1.2.1 Ohm's law	1
1.2.2 Series and parallel resistors	2
1.2.3 Power dissipation	2
1.3 Nonideal properties	3
1.4 Fixed resistor	3
1.4.1 Lead arrangements	3
1.4.2 Carbon composition	3
1.4.3 Carbon pile	4
1.4.4 Carbon film	4
1.4.5 Printed carbon resistor	4
1.4.6 Thick and thin film	4
1.4.7 Metal film	5
1.4.8 Metal oxide film	5
1.4.9 Wire wound	5
1.4.10 Foil resistor	6
1.4.11 Ammeter shunts	6
1.4.12 Grid resistor	6
1.4.13 Special varieties	6
1.5 Variable resistors	6
1.5.1 Adjustable resistors	7
1.5.2 Potentiometers	7
1.5.3 Resistance decade boxes	7
1.5.4 Special devices	7
1.6 Measurement	7
1.7 Standards	8
1.7.1 Production resistors	8
1.7.2 Resistance standards	8
1.8 Resistor marking	8
1.8.1 Preferred values	9

1.8.2	SMT resistors	9
1.8.3	Industrial type designation	9
1.9	Electrical and thermal noise	10
1.10	Failure modes	10
1.11	See also	11
1.12	References	11
1.13	External links	12
2	Electronic color code	13
2.1	Resistor color-coding	13
2.2	Capacitor color-coding	14
2.3	Diode part number	15
2.4	Postage stamp capacitors and war standard coding	15
2.5	Mnemonics	15
2.6	Examples	15
2.7	Transformer wiring color codes	16
2.8	Other wiring codes	16
2.9	See also	16
2.10	References	16
2.11	External links	17
3	Surface-mount technology	18
3.1	History	18
3.2	Terms	19
3.3	Assembly techniques	19
3.4	Advantages	20
3.5	Disadvantages	20
3.6	Rework	20
3.6.1	Infrared	21
3.6.2	Hot gas	21
3.7	Packages	21
3.8	Identification	25
3.8.1	Resistors	25
3.8.2	Capacitors	26
3.8.3	Inductors	26
3.8.4	Discrete semiconductors	26
3.8.5	Integrated circuits	27
3.9	See also	27
3.10	References	27
3.11	Further reading	28
3.12	External links	28

4	Operational amplifier	29
4.1	Operation	29
4.1.1	Open loop amplifier	29
4.1.2	Closed loop	30
4.2	Op-amp characteristics	30
4.2.1	Ideal op-amps	30
4.2.2	Real op-amps	31
4.3	Internal circuitry of 741-type op-amp	34
4.3.1	Architecture	34
4.3.2	Biasing circuits	35
4.3.3	Small-signal differential mode	35
4.3.4	Other linear characteristics	36
4.3.5	Non-linear characteristics	37
4.3.6	Applicability considerations	37
4.4	Classification	37
4.5	Applications	38
4.5.1	Use in electronics system design	38
4.5.2	Applications without using any feedback	38
4.5.3	Positive feedback applications	38
4.5.4	Negative feedback applications	38
4.5.5	Other applications	39
4.6	Historical timeline	40
4.7	See also	42
4.8	Notes	42
4.9	References	42
4.10	Further reading	43
4.11	External links	43
5	Comparator	45
5.1	Differential Voltage	45
5.2	Op-amp voltage comparator	45
5.3	Working	46
5.4	Key specifications	46
5.4.1	Speed and power	46
5.4.2	Hysteresis	47
5.4.3	Output type	47
5.4.4	Internal reference	47
5.4.5	Continuous versus clocked	47
5.5	Applications	48
5.5.1	Null detectors	48
5.5.2	Zero-crossing detectors	48
5.5.3	Relaxation oscillator	48

5.5.4	Level shifter	48
5.5.5	Analog-to-digital converters	48
5.5.6	Window detectors	48
5.6	See also	48
5.7	References	48
5.8	External links	49
6	Flash ADC	50
6.1	Benefits and drawbacks	50
6.2	Implementation	50
6.3	Folding ADC	51
6.4	Application	51
6.5	References	51
7	Network analysis (electrical circuits)	52
7.1	Definitions	52
7.2	Equivalent circuits	52
7.2.1	Impedances in series and in parallel	52
7.2.2	Delta-wye transformation	53
7.2.3	General form of network node elimination	53
7.2.4	Source transformation	53
7.3	Simple networks	54
7.3.1	Voltage division of series components	54
7.3.2	Current division of parallel components	54
7.4	Nodal analysis	54
7.5	Mesh analysis	54
7.6	Superposition	54
7.7	Choice of method	54
7.8	Transfer function	55
7.8.1	Two terminal component transfer functions	55
7.8.2	Two port network transfer function	55
7.9	Non-linear networks	56
7.9.1	Constitutive equations	56
7.9.2	Existence, uniqueness and stability	56
7.9.3	Methods	56
7.9.4	Time-varying components	58
7.10	See also	58
7.11	References	58
7.12	External links	59
7.13	Text and image sources, contributors, and licenses	60
7.13.1	Text	60
7.13.2	Images	62

7.13.3 Content license 67

Chapter 1

Resistor

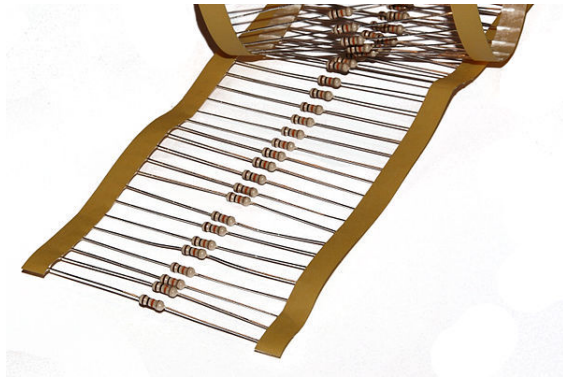

Axial-lead resistors on tape. The component is cut from the tape during assembly and the part is inserted into the board.

A **resistor** is a passive two-terminal electrical component that implements electrical resistance as a circuit element. Resistors act to reduce current flow, and, at the same time, act to lower voltage levels within circuits. In electronic circuits resistors are used to limit current flow, to adjust signal levels, bias active elements, terminate transmission lines among other uses. High-power resistors that can dissipate many watts of electrical power as heat may be used as part of motor controls, in power distribution systems, or as test loads for generators. Fixed resistors have resistances that only change slightly with temperature, time or operating voltage. Variable resistors can be used to adjust circuit elements (such as a volume control or a lamp dimmer), or as sensing devices for heat, light, humidity, force, or chemical activity.

Resistors are common elements of electrical networks and electronic circuits and are ubiquitous in electronic equipment. Practical resistors as discrete components can be composed of various compounds and forms. Resistors are also implemented within integrated circuits.

The electrical function of a resistor is specified by its resistance: common commercial resistors are manufactured over a range of more than nine orders of magnitude. The nominal value of the resistance will fall within a manufacturing tolerance.

1.1 Electronic symbols and notation

Main article: [Electronic symbol](#)

Two typical schematic diagram symbols are as follows;

- (a) resistor, (b) rheostat (variable resistor), and (c) potentiometer
- IEC resistor symbol

The notation to state a resistor's value in a circuit diagram varies, too. The European notation BS 1852 avoids using a decimal separator, and replaces the decimal separator with the SI prefix symbol for the particular value. For example, *8k2* in a circuit diagram indicates a resistor value of 8.2 k Ω . Additional zeros imply tighter tolerance, for example *15M0*. When the value can be expressed without the need for an SI prefix, an 'R' is used instead of the decimal separator. For example, *1R2* indicates 1.2 Ω , and *18R* indicates 18 Ω . The use of a SI prefix symbol or the letter 'R' circumvents the problem that decimal separators tend to 'disappear' when photocopying a printed circuit diagram.

1.2 Theory of operation

1.2.1 Ohm's law

Main article: [Ohm's law](#)

The behavior of an ideal resistor is dictated by the relationship specified by Ohm's law:

$$V = I \cdot R.$$

Ohm's law states that the voltage (V) across a resistor is proportional to the current (I), where the constant of proportionality is the resistance (R). For example, if a 300 ohm resistor is attached across the terminals of a 12 volt

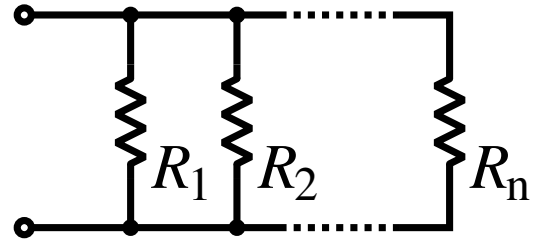
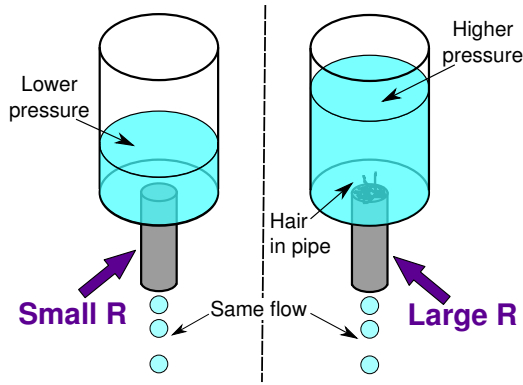

$$\frac{1}{R_{eq}} = \frac{1}{R_1} + \frac{1}{R_2} + \dots + \frac{1}{R_n}$$

The hydraulic analogy compares electric current flowing through circuits to water flowing through pipes. When a pipe (left) is filled with hair (right), it takes a larger pressure to achieve the same flow of water. Pushing electric current through a large resistance is like pushing water through a pipe clogged with hair: It requires a larger push (voltage drop) to drive the same flow (electric current).^[1]

So, for example, a 10 ohm resistor connected in parallel with a 5 ohm resistor and a 15 ohm resistor will produce the inverse of $1/10+1/5+1/15$ ohms of resistance, or $1/(.1+.2+.067)=2.725$ ohms.

battery, then a current of $12 / 300 = 0.04$ amperes flows through that resistor.

A resistor network that is a combination of parallel and series connections can be broken up into smaller parts that are either one or the other. Some complex networks of resistors cannot be resolved in this manner, requiring more sophisticated circuit analysis. Generally, the Y-Δ transform, or matrix methods can be used to solve such problems.^{[2][3][4]}

Practical resistors also have some inductance and capacitance which will also affect the relation between voltage and current in alternating current circuits.

The ohm (symbol: Ω) is the SI unit of electrical resistance, named after Georg Simon Ohm. An ohm is equivalent to a volt per ampere. Since resistors are specified and manufactured over a very large range of values, the derived units of milliohm ($1 \text{ m}\Omega = 10^{-3} \Omega$), kilohm ($1 \text{ k}\Omega = 10^3 \Omega$), and megohm ($1 \text{ M}\Omega = 10^6 \Omega$) are also in common usage.

1.2.3 Power dissipation

1.2.2 Series and parallel resistors

At any instant of time, the power P (watts) consumed by a resistor of resistance R (ohms) is calculated as: $P = I^2 R = IV = \frac{V^2}{R}$ where V (volts) is the voltage across the resistor and I (amps) is the current flowing through it. Using Ohm's law, the two other forms can be derived. This power is converted into heat which must be dissipated by the resistor's package before its temperature rises excessively.

Main article: Series and parallel circuits

Resistors are rated according to their maximum power dissipation. Most discrete resistors in solid-state electronic systems absorb much less than a watt of electrical power and require no attention to their power rating. Such resistors in their discrete form, including most of the packages detailed below, are typically rated as 1/10, 1/8, or 1/4 watt.

The total resistance of resistors connected in series is the sum of their individual resistance values.



$$R_{eq} = R_1 + R_2 + \dots + R_n$$



An aluminium-housed power resistor rated for 50 W when heat-sinked

The total resistance of resistors connected in parallel is the reciprocal of the sum of the reciprocals of the individual resistors.

Resistors required to dissipate substantial amounts of power, particularly used in power supplies, power con-

version circuits, and power amplifiers, are generally referred to as *power resistors*; this designation is loosely applied to resistors with power ratings of 1 watt or greater. Power resistors are physically larger and may not use the preferred values, color codes, and external packages described below.

If the average power dissipated by a resistor is more than its power rating, damage to the resistor may occur, permanently altering its resistance; this is distinct from the reversible change in resistance due to its **temperature coefficient** when it warms. Excessive power dissipation may raise the temperature of the resistor to a point where it can burn the circuit board or adjacent components, or even cause a fire. There are flameproof resistors that fail (open circuit) before they overheat dangerously.

Since poor air circulation, high altitude, or high **operating temperatures** may occur, resistors may be specified with higher rated dissipation than will be experienced in service.

Some types and ratings of resistors may also have a maximum voltage rating; this may limit available power dissipation for higher resistance values.

1.3 Nonideal properties

Practical resistors have a series **inductance** and a small parallel **capacitance**; these specifications can be important in high-frequency applications. In a **low-noise amplifier** or **pre-amp**, the noise characteristics of a resistor may be an issue.

The **temperature coefficient** of the resistance may also be of concern in some precision applications.

The unwanted inductance, excess noise, and temperature coefficient are mainly dependent on the technology used in manufacturing the resistor. They are not normally specified individually for a particular family of resistors manufactured using a particular technology.^[5] A family of discrete resistors is also characterized according to its form factor, that is, the size of the device and the position of its leads (or terminals) which is relevant in the practical manufacturing of circuits using them.

Practical resistors are also specified as having a maximum **power rating** which must exceed the anticipated power dissipation of that resistor in a particular circuit: this is mainly of concern in power electronics applications. Resistors with higher power ratings are physically larger and may require **heat sinks**. In a high-voltage circuit, attention must sometimes be paid to the rated maximum working voltage of the resistor. While there is no minimum working voltage for a given resistor, failure to account for a resistor's maximum rating may cause the resistor to incinerate when current is run through it.

1.4 Fixed resistor

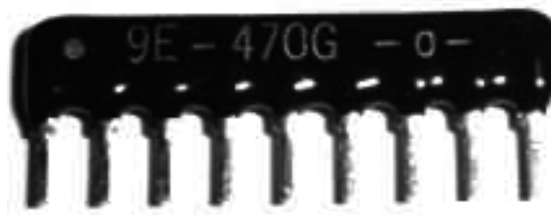

A single in line (SIL) resistor package with 8 individual, 47 ohm resistors. One end of each resistor is connected to a separate pin and the other ends are all connected together to the remaining (common) pin – pin 1, at the end identified by the white dot.

1.4.1 Lead arrangements



Resistors with wire leads for through-hole mounting

Through-hole components typically have leads leaving the body axially. Others have leads coming off their body radially instead of parallel to the resistor axis. Other components may be **SMT** (surface mount technology) while high power resistors may have one of their leads designed into the **heat sink**.

1.4.2 Carbon composition

Carbon composition resistors consist of a solid cylindrical resistive element with embedded wire leads or metal end caps to which the lead wires are attached. The body of the resistor is protected with paint or plastic. Early 20th-century carbon composition resistors had uninsulated bodies; the lead wires were wrapped around the ends of the resistance element rod and soldered. The completed resistor was painted for color-coding of its value.

The resistive element is made from a mixture of finely ground (powdered) carbon and an insulating material (usually ceramic). A resin holds the mixture together. The resistance is determined by the ratio of the fill material (the powdered ceramic) to the carbon. Higher



Three carbon composition resistors in a 1960s valve (vacuum tube) radio

concentrations of carbon—a good conductor—result in lower resistance. Carbon composition resistors were commonly used in the 1960s and earlier, but are not so popular for general use now as other types have better specifications, such as tolerance, voltage dependence, and stress (carbon composition resistors will change value when stressed with over-voltages). Moreover, if internal moisture content (from exposure for some length of time to a humid environment) is significant, soldering heat will create a non-reversible change in resistance value. Carbon composition resistors have poor stability with time and were consequently factory sorted to, at best, only 5% tolerance.^[6] These resistors, however, if never subjected to overvoltage nor overheating were remarkably reliable considering the component's size.^[7]

Carbon composition resistors are still available, but comparatively quite costly. Values ranged from fractions of an ohm to 22 megohms. Due to their high price, these resistors are no longer used in most applications. However, they are used in power supplies and welding controls.^[7]

1.4.3 Carbon pile

A carbon pile resistor is made of a stack of carbon disks compressed between two metal contact plates. Adjusting the clamping pressure changes the resistance between the plates. These resistors are used when an adjustable load is required, for example in testing automotive batteries or radio transmitters. A carbon pile resistor can also be used as a speed control for small motors in household appliances (sewing machines, hand-held mixers) with ratings up to a few hundred watts.^[8] A carbon pile resistor can be incorporated in automatic voltage regulators for generators, where the carbon pile controls the field current to maintain relatively constant voltage.^[9] The principle is also applied in the carbon microphone.

1.4.4 Carbon film

A carbon film is deposited on an insulating substrate, and a helix is cut in it to create a long, narrow resis-

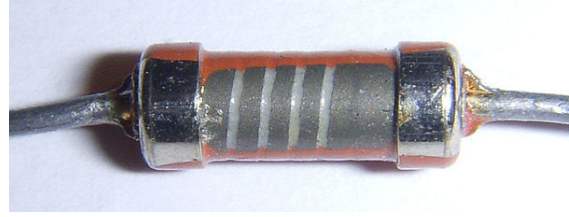

Carbon film resistor with exposed carbon spiral (Tesla TR-212 1 k Ω)

tive path. Varying shapes, coupled with the resistivity of amorphous carbon (ranging from 500 to 800 $\mu\Omega$ m), can provide a wide range of resistance values. Compared to carbon composition they feature low noise, because of the precise distribution of the pure graphite without binding.^[10] Carbon film resistors feature a power rating range of 0.125 W to 5 W at 70 °C. Resistances available range from 1 ohm to 10 megohm. The carbon film resistor has an operating temperature range of -55 °C to 155 °C. It has 200 to 600 volts maximum working voltage range. Special carbon film resistors are used in applications requiring high pulse stability.^[7]

1.4.5 Printed carbon resistor

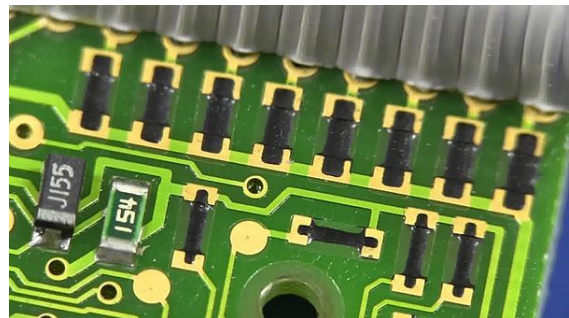

A carbon resistor printed directly onto the SMD pads on a PCB. Inside a 1989 vintage Psion II Organiser

Carbon composition resistors can be printed directly onto printed circuit board (PCB) substrates as part of the PCB manufacturing process. Although this technique is more common on hybrid PCB modules, it can also be used on standard fibreglass PCBs. Tolerances are typically quite large, and can be in the order of 30%. A typical application would be non-critical pull-up resistors.

1.4.6 Thick and thin film

Thick film resistors became popular during the 1970s, and most SMD (surface mount device) resistors today are of this type. The resistive element of thick films is 1000 times thicker than thin films,^[11] but the principal difference is how the film is applied to the cylinder (axial resistors) or the surface (SMD resistors).

Thin film resistors are made by **sputtering** (a method of **vacuum deposition**) the resistive material onto an insulating substrate. The film is then etched in a similar manner to the old (subtractive) process for making printed circuit boards; that is, the surface is coated with a **photosensitive material**, then covered by a pattern film, irradiated with **ultraviolet light**, and then the exposed photosensitive coating is developed, and underlying thin film is etched away.

Thick film resistors are manufactured using screen and stencil printing processes.^[7]

Because the time during which the sputtering is performed can be controlled, the thickness of the thin film can be accurately controlled. The type of material is also usually different consisting of one or more ceramic (cermet) conductors such as **tantalum nitride** (TaN), **ruthenium oxide** (RuO₂), **lead oxide** (PbO), **bismuth ruthenate** (Bi₂Ru₂O₇), **nickel chromium** (NiCr), or **bismuth iridate** (Bi₂Ir₂O₇).

The resistance of both thin and thick film resistors after manufacture is not highly accurate; they are usually trimmed to an accurate value by **abrasive** or **laser trimming**. Thin film resistors are usually specified with tolerances of 0.1, 0.2, 0.5, or 1%, and with temperature coefficients of 5 to 25 ppm/K. They also have much lower noise levels, on the level of 10–100 times less than thick film resistors.

Thick film resistors may use the same conductive ceramics, but they are mixed with **sintered** (powdered) glass and a carrier liquid so that the composite can be **screen-printed**. This composite of glass and conductive ceramic (cermet) material is then fused (baked) in an oven at about 850 °C.

Thick film resistors, when first manufactured, had tolerances of 5%, but standard tolerances have improved to 2% or 1% in the last few decades. Temperature coefficients of thick film resistors are high, typically ± 200 or ± 250 ppm/K; a 40 kelvin (70 °F) temperature change can change the resistance by 1%.

Thin film resistors are usually far more expensive than thick film resistors. For example, SMD thin film resistors, with 0.5% tolerances, and with 25 ppm/K temperature coefficients, when bought in full size reel quantities, are about twice the cost of 1%, 250 ppm/K thick film resistors.

1.4.7 Metal film

A common type of axial resistor today is referred to as a metal-film resistor. Metal electrode leadless face

(MELF) resistors often use the same technology, but are cylindrically shaped resistors designed for surface mounting. Note that other types of resistors (e.g., carbon composition) are also available in MELF packages.

Metal film resistors are usually coated with nickel chromium (NiCr), but might be coated with any of the cermet materials listed above for thin film resistors. Unlike thin film resistors, the material may be applied using different techniques than sputtering (though this is one of the techniques). Also, unlike thin-film resistors, the resistance value is determined by cutting a helix through the coating rather than by etching. (This is similar to the way carbon resistors are made.) The result is a reasonable tolerance (0.5%, 1%, or 2%) and a temperature coefficient that is generally between 50 and 100 ppm/K.^[12] Metal film resistors possess good noise characteristics and low non-linearity due to a low voltage coefficient. Also beneficial are their efficient tolerance, temperature coefficient and stability.^[7]

1.4.8 Metal oxide film

Metal-oxide film resistors are made of metal oxides such as tin oxide. This results in a higher operating temperature and greater stability/reliability than Metal film. They are used in applications with high endurance demands.

1.4.9 Wire wound



High-power wire wound resistors used for dynamic braking on an electric railway car. Such resistors may dissipate many kilowatts for an extended length of time.

Wirewound resistors are commonly made by winding a metal wire, usually **nichrome**, around a ceramic, plastic, or fiberglass core. The ends of the wire are soldered or welded to two caps or rings, attached to the ends of the core. The assembly is protected with a layer of paint, molded plastic, or an enamel coating baked at high temperature. These resistors are designed to withstand unusually high temperatures of up to 450 °C.^[7] Wire leads in low power wirewound resistors are usually between 0.6 and 0.8 mm in diameter and tinned for ease of solder-

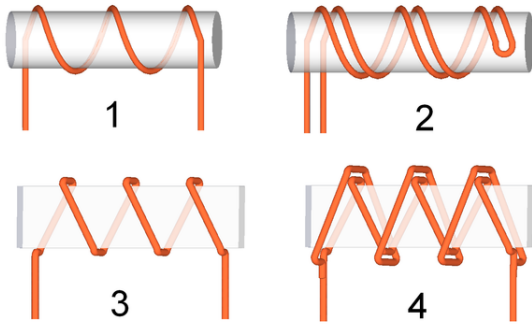

Types of windings in wire resistors:

1. common
2. bifilar
3. common on a thin former
4. Ayrton-Perry

ing. For higher power wirewound resistors, either a ceramic outer case or an aluminum outer case on top of an insulating layer is used – if the outer case is ceramic, such resistors are sometimes described as “cement” resistors, though they do not actually contain any traditional cement. The aluminum-cased types are designed to be attached to a heat sink to dissipate the heat; the rated power is dependent on being used with a suitable heat sink, e.g., a 50 W power rated resistor will overheat at a fraction of the power dissipation if not used with a heat sink. Large wirewound resistors may be rated for 1,000 watts or more.

Because wirewound resistors are coils they have more undesirable inductance than other types of resistor, although winding the wire in sections with alternately reversed direction can minimize inductance. Other techniques employ bifilar winding, or a flat thin former (to reduce cross-section area of the coil). For the most demanding circuits, resistors with Ayrton-Perry winding are used.

Applications of wirewound resistors are similar to those of composition resistors with the exception of the high frequency. The high frequency response of wirewound resistors is substantially worse than that of a composition resistor.^[7]

1.4.10 Foil resistor

The primary resistance element of a foil resistor is a special alloy foil several micrometers thick. Since their introduction in the 1960s, foil resistors have had the best precision and stability of any resistor available. One of the important parameters influencing stability is the temperature coefficient of resistance (TCR). The TCR of foil resistors is extremely low, and has been further improved over the years. One range of ultra-precision foil resistors offers a TCR of 0.14 ppm/°C, tolerance $\pm 0.005\%$, long-term stability (1 year) 25 ppm, (3 year) 50 ppm (further improved 5-fold by hermetic sealing), stability under load (2000 hours) 0.03%, thermal EMF 0.1 $\mu\text{V}/^\circ\text{C}$, noise -42

dB, voltage coefficient 0.1 ppm/V, inductance 0.08 μH , capacitance 0.5 pF.^[13]

1.4.11 Ammeter shunts

An ammeter shunt is a special type of current-sensing resistor, having four terminals and a value in milliohms or even micro-ohms. Current-measuring instruments, by themselves, can usually accept only limited currents. To measure high currents, the current passes through the shunt across which the voltage drop is measured and interpreted as current. A typical shunt consists of two solid metal blocks, sometimes brass, mounted on an insulating base. Between the blocks, and soldered or brazed to them, are one or more strips of low temperature coefficient of resistance (TCR) manganin alloy. Large bolts threaded into the blocks make the current connections, while much smaller screws provide volt meter connections. Shunts are rated by full-scale current, and often have a voltage drop of 50 mV at rated current. Such meters are adapted to the shunt full current rating by using an appropriately marked dial face; no change need to be made to the other parts of the meter.

1.4.12 Grid resistor

In heavy-duty industrial high-current applications, a grid resistor is a large convection-cooled lattice of stamped metal alloy strips connected in rows between two electrodes. Such industrial grade resistors can be as large as a refrigerator; some designs can handle over 500 amperes of current, with a range of resistances extending lower than 0.04 ohms. They are used in applications such as dynamic braking and load banking for locomotives and trams, neutral grounding for industrial AC distribution, control loads for cranes and heavy equipment, load testing of generators and harmonic filtering for electric substations.^{[14][15]}

The term *grid resistor* is sometimes used to describe a resistor of any type connected to the control grid of a vacuum tube. This is not a resistor technology; it is an electronic circuit topology.

1.4.13 Special varieties

- Cermet
- Phenolic
- Tantalum
- Water resistor

1.5 Variable resistors

1.5.1 Adjustable resistors

A resistor may have one or more fixed tapping points so that the resistance can be changed by moving the connecting wires to different terminals. Some wirewound power resistors have a tapping point that can slide along the resistance element, allowing a larger or smaller part of the resistance to be used.

Where continuous adjustment of the resistance value during operation of equipment is required, the sliding resistance tap can be connected to a knob accessible to an operator. Such a device is called a **rheostat** and has two terminals.

1.5.2 Potentiometers

Main article: Potentiometer

A common element in electronic devices is a three-terminal resistor with a continuously adjustable tapping point controlled by rotation of a shaft or knob. These variable resistors are known as **potentiometers** when all three terminals are present, since they act as a continuously adjustable **voltage divider**. A common example is a volume control for a radio receiver.^[16]

Accurate, high-resolution panel-mounted potentiometers (or “pots”) have resistance elements typically wirewound on a helical mandrel, although some include a conductive-plastic resistance coating over the wire to improve resolution. These typically offer ten turns of their shafts to cover their full range. They are usually set with dials that include a simple turns counter and a graduated dial. Electronic analog computers used them in quantity for setting coefficients, and delayed-sweep oscilloscopes of recent decades included one on their panels.

1.5.3 Resistance decade boxes



Resistance decade box “KURBELWIDERSTAND”, made in former East Germany.

A resistance decade box or resistor substitution box is a unit containing resistors of many values, with one or more mechanical switches which allow any one of various discrete resistances offered by the box to be dialed in. Usually the resistance is accurate to high precision, ranging from laboratory/calibration grade accuracy of 20 parts per million, to field grade at 1%. Inexpensive boxes with lesser accuracy are also available. All types offer a convenient way of selecting and quickly changing a resistance in laboratory, experimental and development work without needing to attach resistors one by one, or even stock each value. The range of resistance provided, the maximum resolution, and the accuracy characterize the box. For example, one box offers resistances from 0 to 100 megohms, maximum resolution 0.1 ohm, accuracy 0.1%.^[17]

1.5.4 Special devices

There are various devices whose resistance changes with various quantities. The resistance of **NTC thermistors** exhibit a strong negative temperature coefficient, making them useful for measuring temperatures. Since their resistance can be large until they are allowed to heat up due to the passage of current, they are also commonly used to prevent excessive **current surges** when equipment is powered on. Similarly, the resistance of a **humistor** varies with humidity. One sort of photodetector, the **photoresistor**, has a resistance which varies with illumination.

The **strain gauge**, invented by Edward E. Simmons and Arthur C. Ruge in 1938, is a type of resistor that changes value with applied strain. A single resistor may be used, or a pair (half bridge), or four resistors connected in a **Wheatstone bridge** configuration. The strain resistor is bonded with adhesive to an object that will be subjected to mechanical strain. With the strain gauge and a filter, amplifier, and analog/digital converter, the strain on an object can be measured.

A related but more recent invention uses a **Quantum Tunneling Composite** to sense mechanical stress. It passes a current whose magnitude can vary by a factor of 10^{12} in response to changes in applied pressure.

1.6 Measurement

The value of a resistor can be measured with an **ohmmeter**, which may be one function of a **multimeter**. Usually, probes on the ends of test leads connect to the resistor. A simple ohmmeter may apply a voltage from a battery across the unknown resistor (with an internal resistor of a known value in series) producing a current which drives a meter movement. The current, in accordance with Ohm’s law, is inversely proportional to the sum of the internal resistance and the resistor being

tested, resulting in an analog meter scale which is very non-linear, calibrated from infinity to 0 ohms. A digital multimeter, using active electronics, may instead pass a specified current through the test resistance. The voltage generated across the test resistance in that case is linearly proportional to its resistance, which is measured and displayed. In either case the low-resistance ranges of the meter pass much more current through the test leads than do high-resistance ranges, in order for the voltages present to be at reasonable levels (generally below 10 volts) but still measurable.

Measuring low-value resistors, such as fractional-ohm resistors, with acceptable accuracy requires **four-terminal connections**. One pair of terminals applies a known, calibrated current to the resistor, while the other pair senses the voltage drop across the resistor. Some laboratory quality ohmmeters, especially milliohmmeters, and even some of the better digital multimeters sense using four input terminals for this purpose, which may be used with special test leads. Each of the two so-called **Kelvin clips** has a pair of jaws insulated from each other. One side of each clip applies the measuring current, while the other connections are only to sense the voltage drop. The resistance is again calculated using Ohm's Law as the measured voltage divided by the applied current.

1.7 Standards

1.7.1 Production resistors

Resistor characteristics are quantified and reported using various national standards. In the US, MIL-STD-202^[18] contains the relevant test methods to which other standards refer.

There are various standards specifying properties of resistors for use in equipment:

- BS 1852
- EIA-RS-279
- MIL-PRF-26
- MIL-PRF-39007 (Fixed Power, established reliability)
- MIL-PRF-55342 (Surface-mount thick and thin film)
- MIL-PRF-914
- MIL-R-11 STANDARD CANCELED
- MIL-R-39017 (Fixed, General Purpose, Established Reliability)
- MIL-PRF-32159 (zero ohm jumpers)

There are other United States military procurement MIL-R- standards.

1.7.2 Resistance standards

The **primary standard** for resistance, the “mercury ohm” was initially defined in 1884 in as a column of mercury 106.3 cm long and 1 square millimeter in cross-section, at 0 degrees Celsius. Difficulties in precisely measuring the physical constants to replicate this standard result in variations of as much as 30 ppm. From 1900 the mercury ohm was replaced with a precision machined plate of **manganin**.^[19] Since 1990 the international resistance standard has been based on the **quantized Hall effect** discovered by **Klaus von Klitzing**, for which he won the Nobel Prize in Physics in 1985.^[20]

Resistors of extremely high precision are manufactured for **calibration and laboratory use**. They may have four terminals, using one pair to carry an operating current and the other pair to measure the voltage drop; this eliminates errors caused by voltage drops across the lead resistances, because no charge flows through voltage sensing leads. It is important in small value resistors (100–0.0001 ohm) where lead resistance is significant or even comparable with respect to resistance standard value.^[21]

1.8 Resistor marking

Main article: [Electronic color code](#)

Most axial resistors use a pattern of colored stripes to indicate resistance, which also indicate tolerance, and may also be extended to show temperature coefficient and reliability class. Cases are usually tan, brown, blue, or green, though other colors are occasionally found such as dark red or dark gray. The power rating is not usually marked and is deduced from the size.

The color bands of the carbon resistors can be four, five or, six bands. The first two bands represent first two digits to measure their value in ohms. The third band of a four-banded resistor represents multiplier and the fourth band as tolerance. For five and six color-banded resistors, the third band is a third digit, fourth band multiplier and fifth is tolerance. The sixth band represents temperature coefficient in a six-banded resistor.

Surface-mount resistors are marked numerically, if they are big enough to permit marking; more-recent small sizes are impractical to mark.

Early 20th century resistors, essentially uninsulated, were dipped in paint to cover their entire body for color-coding. A second color of paint was applied to one end of the element, and a color dot (or band) in the middle provided the third digit. The rule was “body, tip, dot”, providing two significant digits for value and the decimal multiplier, in that sequence. Default tolerance was $\pm 20\%$. Closer-tolerance resistors had silver ($\pm 10\%$) or gold-colored ($\pm 5\%$) paint on the other end.

1.8.1 Preferred values

Main article: Preferred number

Early resistors were made in more or less arbitrary round numbers; a series might have 100, 125, 150, 200, 300, etc. Resistors as manufactured are subject to a certain percentage tolerance, and it makes sense to manufacture values that correlate with the tolerance, so that the actual value of a resistor overlaps slightly with its neighbors. Wider spacing leaves gaps; narrower spacing increases manufacturing and inventory costs to provide resistors that are more or less interchangeable.

A logical scheme is to produce resistors in a range of values which increase in a **geometric progression**, so that each value is greater than its predecessor by a fixed multiplier or percentage, chosen to match the tolerance of the range. For example, for a tolerance of $\pm 20\%$ it makes sense to have each resistor about 1.5 times its predecessor, covering a decade in 6 values. In practice the factor used is 1.4678, giving values of 1.47, 2.15, 3.16, 4.64, 6.81, 10 for the 1–10 decade (a decade is a range increasing by a factor of 10; 0.1–1 and 10–100 are other examples); these are rounded in practice to 1.5, 2.2, 3.3, 4.7, 6.8, 10; followed, by 15, 22, 33, ... and preceded by ... 0.47, 0.68, 1. This scheme has been adopted as the **E6** series of the IEC 60063 preferred number values. There are also **E12**, **E24**, **E48**, **E96** and **E192** series for components of progressively finer resolution, with 12, 24, 96, and 192 different values within each decade. The actual values used are in the IEC 60063 lists of preferred numbers.

A resistor of 100 ohms $\pm 20\%$ would be expected to have a value between 80 and 120 ohms; its E6 neighbors are 68 (54–82) and 150 (120–180) ohms. A sensible spacing, E6 is used for $\pm 20\%$ components; E12 for $\pm 10\%$; E24 for $\pm 5\%$; E48 for $\pm 2\%$, E96 for $\pm 1\%$; E192 for $\pm 0.5\%$ or better. Resistors are manufactured in values from a few milliohms to about a gigaohm in IEC60063 ranges appropriate for their tolerance. Manufacturers may sort resistors into tolerance-classes based on measurement. Accordingly a selection of 100 ohms resistors with a tolerance of $\pm 10\%$, might not lie just around 100 ohm (but no more than 10% off) as one would expect (a bell-curve), but rather be in two groups – either between 5 to 10% too high or 5 to 10% too low (but not closer to 100 ohm than that) because any resistors the factory had measured as being less than 5% off would have been marked and sold as resistors with only $\pm 5\%$ tolerance or better. When designing a circuit, this may become a consideration.

Earlier power wirewound resistors, such as brown vitreous-enameled types, however, were made with a different system of preferred values, such as some of those mentioned in the first sentence of this section.

1.8.2 SMT resistors

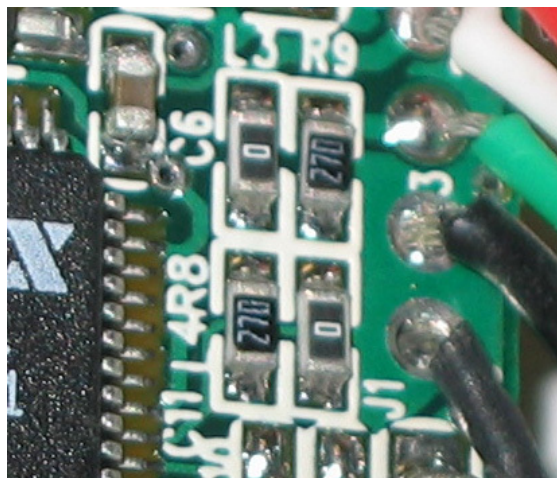

This image shows four surface-mount resistors (the component at the upper left is a capacitor) including two zero-ohm resistors. Zero-ohm links are often used instead of wire links, so that they can be inserted by a resistor-inserting machine. Their resistance is non-zero but negligible.

Surface mounted resistors are printed with numerical values in a code related to that used on axial resistors. Standard-tolerance surface-mount technology (SMT) resistors are marked with a three-digit code, in which the first two digits are the first two significant digits of the value and the third digit is the power of ten (the number of zeroes). For example:

Resistances less than 100 ohms are written: 100, 220, 470. The final zero represents ten to the power zero, which is 1. For example:

Sometimes these values are marked as 10 or 22 to prevent a mistake.

Resistances less than 10 ohms have 'R' to indicate the position of the decimal point (radix point). For example:

Precision resistors are marked with a four-digit code, in which the first three digits are the significant figures and the fourth is the power of ten. For example:

000 and 0000 sometimes appear as values on surface-mount zero-ohm links, since these have (approximately) zero resistance.

More recent surface-mount resistors are too small, physically, to permit practical markings to be applied.

1.8.3 Industrial type designation

Format: [two letters]<space>[resistance value (three digit)]<nospace>[tolerance code(numerical – one digit)]^[22]

1.9 Electrical and thermal noise

Main article: [Noise \(electronics\)](#)

In amplifying faint signals, it is often necessary to minimize electronic noise, particularly in the first stage of amplification. As a dissipative element, even an ideal resistor will naturally produce a randomly fluctuating voltage or “noise” across its terminals. This Johnson–Nyquist noise is a fundamental noise source which depends only upon the temperature and resistance of the resistor, and is predicted by the fluctuation–dissipation theorem. Using a larger value of resistance produces a larger voltage noise, whereas with a smaller value of resistance there will be more current noise, at a given temperature.

The thermal noise of a practical resistor may also be larger than the theoretical prediction and that increase is typically frequency-dependent. Excess noise of a practical resistor is observed only when current flows through it. This is specified in unit of $\mu\text{V}/\text{V}/\text{decade}$ – μV of noise per volt applied across the resistor per decade of frequency. The $\mu\text{V}/\text{V}/\text{decade}$ value is frequently given in dB so that a resistor with a noise index of 0 dB will exhibit 1 μV (rms) of excess noise for each volt across the resistor in each frequency decade. Excess noise is thus an example of $1/f$ noise. Thick-film and carbon composition resistors generate more excess noise than other types at low frequencies. Wire-wound and thin-film resistors are often used for their better noise characteristics. Carbon composition resistors can exhibit a noise index of 0 dB while bulk metal foil resistors may have a noise index of -40 dB, usually making the excess noise of metal foil resistors insignificant.^[23] Thin film surface mount resistors typically have lower noise and better thermal stability than thick film surface mount resistors. Excess noise is also size-dependent: in general excess noise is reduced as the physical size of a resistor is increased (or multiple resistors are used in parallel), as the independently fluctuating resistances of smaller components will tend to average out.

While not an example of “noise” per se, a resistor may act as a thermocouple, producing a small DC voltage differential across it due to the thermoelectric effect if its ends are at different temperatures. This induced DC voltage can degrade the precision of instrumentation amplifiers in particular. Such voltages appear in the junctions of the resistor leads with the circuit board and with the resistor body. Common metal film resistors show such an effect at a magnitude of about $20 \mu\text{V}/^\circ\text{C}$. Some carbon composition resistors can exhibit thermoelectric offsets as high as $400 \mu\text{V}/^\circ\text{C}$, whereas specially constructed resistors can reduce this number to $0.05 \mu\text{V}/^\circ\text{C}$. In applications where the thermoelectric effect may become important, care has to be taken to mount the resistors horizontally to avoid temperature gradients and to mind the air flow over the board.^[24]

1.10 Failure modes

The failure rate of resistors in a properly designed circuit is low compared to other electronic components such as semiconductors and electrolytic capacitors. Damage to resistors most often occurs due to overheating when the average power delivered to it (as computed above) greatly exceeds its ability to dissipate heat (specified by the resistor’s *power rating*). This may be due to a fault external to the circuit, but is frequently caused by the failure of another component (such as a transistor that shorts out) in the circuit connected to the resistor. Operating a resistor too close to its power rating can limit the resistor’s lifespan or cause a significant change in its resistance. A safe design generally uses overrated resistors in power applications to avoid this danger.

Low-power thin-film resistors can be damaged by long-term high-voltage stress, even below maximum specified voltage and below maximum power rating. This is often the case for the startup resistors feeding the SMPS integrated circuit.

When overheated, carbon-film resistors may decrease or increase in resistance.^[25] Carbon film and composition resistors can fail (open circuit) if running close to their maximum dissipation. This is also possible but less likely with metal film and wirewound resistors.

There can also be failure of resistors due to mechanical stress and adverse environmental factors including humidity. If not enclosed, wirewound resistors can corrode.

Surface mount resistors have been known to fail due to the ingress of sulfur into the internal makeup of the resistor. This sulfur chemically reacts with the silver layer to produce non-conductive silver sulfide. The resistor’s impedance goes to infinity. Sulfur resistant and anti-corrosive resistors are sold into automotive, industrial, and military applications. ASTM B809 is an industry standard that tests a part’s susceptibility to sulfur.

An alternative failure mode can be encountered where large value resistors are used (hundreds of kilohms and higher). Resistors are not only specified with a maximum power dissipation, but also for a maximum voltage drop. Exceeding this voltage will cause the resistor to degrade slowly reducing in resistance. The voltage dropped across large value resistors can be exceeded before the power dissipation reaches its limiting value. Since the maximum voltage specified for commonly encountered resistors is a few hundred volts, this is a problem only in applications where these voltages are encountered.

Variable resistors can also degrade in a different manner, typically involving poor contact between the wiper and the body of the resistance. This may be due to dirt or corrosion and is typically perceived as “crackling” as the contact resistance fluctuates; this is especially noticed as the device is adjusted. This is similar to crackling caused by poor contact in switches, and like switches,

potentiometers are to some extent self-cleaning: running the wiper across the resistance may improve the contact. Potentiometers which are seldom adjusted, especially in dirty or harsh environments, are most likely to develop this problem. When self-cleaning of the contact is insufficient, improvement can usually be obtained through the use of contact cleaner (also known as “tuner cleaner”) spray. The crackling noise associated with turning the shaft of a dirty potentiometer in an audio circuit (such as the volume control) is greatly accentuated when an undesired DC voltage is present, often indicating the failure of a DC blocking capacitor in the circuit.

1.11 See also

- thermistor
- piezoresistor
- Circuit design
- Dummy load
- Electrical impedance
- Iron-hydrogen resistor
- Shot noise
- Trimmer (electronics)

1.12 References

- [1] Douglas Wilhelm Harder. “Resistors: A Motor with a Constant Force (Force Source)”. Department of Electrical and Computer Engineering, University of Waterloo. Retrieved 9 November 2014.
- [2] Farago, PS, *An Introduction to Linear Network Analysis*, pp. 18–21, The English Universities Press Ltd, 1961.
- [3] F Y Wu (2004). “Theory of resistor networks: The two-point resistance”. *Journal of Physics A: Mathematical and General* **37** (26): 6653. doi:10.1088/0305-4470/37/26/004.
- [4] Fa Yueh Wu; Chen Ning Yang (15 March 2009). *Exactly Solved Models: A Journey in Statistical Mechanics : Selected Papers with Commentaries (1963–2008)*. World Scientific. pp. 489–. ISBN 978-981-281-388-6. Retrieved 14 May 2012.
- [5] A family of resistors may also be characterized according to its *critical resistance*. Applying a constant voltage across resistors in that family below the critical resistance will exceed the maximum power rating first; resistances larger than the critical resistance will fail first from exceeding the maximum voltage rating. See Wendy Middleton; Mac E. Van Valkenburg (2002). *Reference data for engineers: radio, electronics, computer, and communications* (9 ed.). Newnes. pp. 5–10. ISBN 0-7506-7291-9.
- [6] James H. Harter, Paul Y. Lin, *Essentials of electric circuits*, pp. 96–97, Reston Publishing Company, 1982 ISBN 0-8359-1767-3.
- [7] Vishay Beyschlag *Basics of Linear Fixed Resistors Application Note*, Document Number 28771, 2008.
- [8] C. G. Morris (ed) *Academic Press Dictionary of Science and Technology*, Gulf Professional Publishing, 1992 ISBN 0122004000, page 360
- [9] *Principles of automotive vehicles* United States. Dept. of the Army, 1985 page 13-13
- [10] “Carbon Film Resistor”. *The Resistorguide*. Retrieved 10 March 2013.
- [11] “Thick Film and Thin Film”. Digi-Key (SEI). Retrieved 23 July 2011.
- [12] Kenneth A. Kuhn. “Measuring the Temperature Coefficient of a Resistor”. Retrieved 2010-03-18.
- [13] “Alpha Electronics Corp. Metal Foil Resistors”. Alphaelec.co.jp. Retrieved 2008-09-22.
- [14] Milwaukee Resistor Corporation. “Grid Resistors: High Power/High Current”. Milwaukeeresistor.com. Retrieved on 2012-05-14.
- [15] Avtron Loadbank. “Grid Resistors”. Avtron.com. Retrieved on 2012-05-14.
- [16] Digitally controlled receivers may not have an analog volume control and use other methods to adjust volume.
- [17] “Decade Box – Resistance Decade Boxes”. Ietlabs.com. Retrieved 2008-09-22.
- [18] “Test method standard: electronic and electrical component parts”. Department of Defense.
- [19] Stability of Double-Walled Manganin Resistors. NIST.gov
- [20] Klaus von Klitzing The Quantized Hall Effect. Nobel lecture, December 9, 1985. nobelprize.org
- [21] “Standard Resistance Unit Type 4737B”. Tinsley.co.uk. Retrieved 2008-09-22.
- [22] *Electronics and Communications Simplified* by A. K. Maini, 9thEd., Khanna Publications (India)
- [23] *Audio Noise Reduction Through the Use of Bulk Metal Foil Resistors – “Hear the Difference”.*, Application note AN0003, Vishay Intertechnology Inc, 12 July 2005.
- [24] Walt Jung. “Chapter 7 – Hardware and Housekeeping Techniques”. *Op Amp Applications Handbook*. p. 7.11. ISBN 0-7506-7844-5.
- [25] “Electronic components – resistors”. *Inspector’s Technical Guide*. US Food and Drug Administration. 1978-01-16. Archived from the original on 2008-04-03. Retrieved 2008-06-11.

1.13 External links

- 4-terminal resistors – How ultra-precise resistors work
- Beginner's guide to potentiometers, including description of different tapers
- Color Coded Resistance Calculator – archived with WayBack Machine
- Resistor Types – Does It Matter?
- Standard Resistors & Capacitor Values That Industry Manufactures
- Ask The Applications Engineer – Difference between types of resistors
- Resistors and their uses
- Thick film resistors and heaters

Chapter 2

Electronic color code

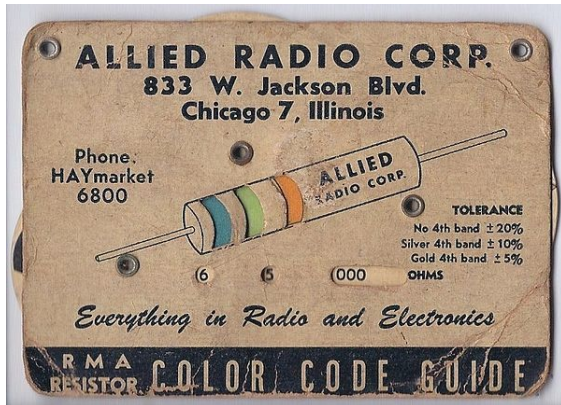

RMA (Radio Manufacturers Association) Resistor Color Code Guide, c. 1945-1955.

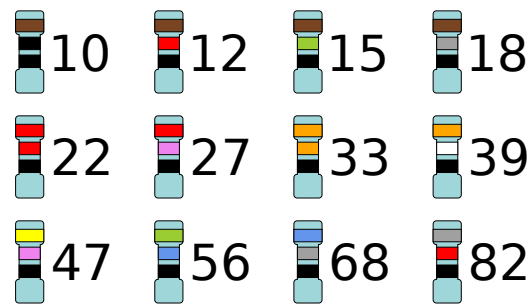

One decade of the E12 series (there are twelve preferred values per decade of values) shown with their electronic color codes on resistors

The **electronic color code** is used to indicate the values or ratings of electronic components, usually for resistors, but also for capacitors, inductors, and others. A separate code, the 25-pair color code, is used to identify wires in some telecommunications cables.

The electronic color code was developed in the early 1920s by the Radio Manufacturers Association (now part of Electronic Industries Alliance^[1] (EIA)), and was published as EIA-RS-279. The current international standard is IEC 60062.^[2]

Colorbands were used because they were easily and cheaply printed on tiny components. However, there were drawbacks, especially for color blind people. Overheating of a component or dirt accumulation, may make it impossible to distinguish brown from red or orange. Advances in printing technology have now made printed numbers practical on small components. Where passive components come in surface mount packages, their values will be identified with printed alphanumeric codes instead of a color code.



A 100 kΩ, 5% axial-lead resistor

2.1 Resistor color-coding

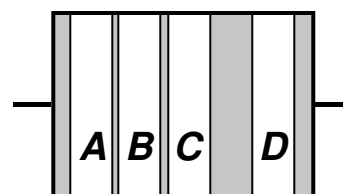



A 0 Ω resistor, marked with a single black band



A 2260 ohm, 1% precision resistor with 5 color bands (E96 series), from top 2-2-6-1-1; the last two brown bands indicate the multiplier ($\times 10$), and the 1% tolerance. The larger gap before the tolerance band is somewhat difficult to distinguish.

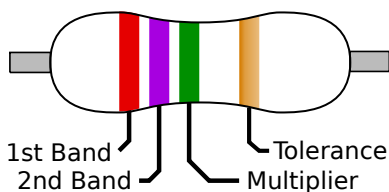

To distinguish left from right there is a gap between the

C and D bands.

- band **A** is the first significant figure of component value (left side)
- band **B** is the second significant figure (some precision resistors have a third significant figure, and thus five bands).
- band **C** is the decimal multiplier
- band **D** if present, indicates tolerance of value in percent (no band means 20%)

For example, a resistor with bands of *yellow, violet, red, and gold* will have first digit 4 (yellow in table below), second digit 7 (violet), followed by 2 (red) zeros: 4,700 ohms. Gold signifies that the tolerance is $\pm 5\%$, so the real resistance could lie anywhere between 4,465 and 4,935 ohms.

Resistors manufactured for military use may also include a fifth band which indicates component failure rate (reliability); refer to MIL-HDBK-199 for further details.

Tight tolerance resistors may have three bands for significant figures rather than two, or an additional band indicating temperature coefficient, in units of ppm/K.

All coded components will have at least two value bands and a multiplier; other bands are optional.

The standard color code per EN 60062:2005 is as follows:

Resistors use preferred numbers for their specific values, which are determined by their tolerance. These values repeat for every decade of magnitude: 6.8, 68, 680, and so forth. In the E24 series the values are related by the 24th root of 10, while E12 series are related by the 12th root of 10, and E6 series by the 6th root of 10. The tolerance of device values is arranged so that every value corresponds to a preferred number, within the required tolerance.

Zero ohm resistors are made as lengths of wire wrapped in a resistor-shaped body which can be substituted for another resistor value in automatic insertion equipment. They are marked with a single black band.^[4]

The 'body-end-dot' or 'body-tip-spot' system was used for radial-lead (and other cylindrical) composition resistors sometimes still found in very old equipment; the first band was given by the body color, the second band by the color of the end of the resistor, and the multiplier by a dot or band around the middle of the resistor. The other end of the resistor was colored gold or silver to give the tolerance, otherwise it was 20%.^[5]

2.2 Capacitor color-coding

Capacitors may be marked with 4 or more colored bands or dots. The colors encode the first and second most significant digits of the value, and the third color the decimal

multiplier in picofarads. Additional bands have meanings which may vary from one type to another. Low-tolerance capacitors may begin with the first 3 (rather than 2) digits of the value. It is usually, but not always, possible to work out what scheme is used by the particular colors used. Cylindrical capacitors marked with bands may look like resistors.

*or ± 0.5 pF, whichever is greater.

Extra bands on ceramic capacitors will identify the voltage rating class and temperature coefficient characteristics.^[5] A broad black band was applied to some tubular paper capacitors to indicate the end that had the outer electrode; this allowed this end to be connected to chassis ground to provide some shielding against hum and noise pickup.

Polyester film and “gum drop” tantalum electrolytic capacitors are also color-coded to give the value, working voltage and tolerance.

2.3 Diode part number

The part number for diodes was sometimes also encoded as colored rings around the diode, using the same numerals as for other parts. The JEDEC “1N” prefix was assumed, and the balance of the part number was given by three or four rings.

2.4 Postage stamp capacitors and war standard coding

Capacitors of the rectangular ‘postage stamp’ form made for military use during World War II used *American War Standard* (AWS) or *Joint Army Navy* (JAN) coding in six dots stamped on the capacitor. An arrow on the top row of dots pointed to the right, indicating the reading order. From left to right the top dots were: either black, indicating JAN mica, or silver, indicating AWS paper; first significant digit; and second significant digit. The bottom three dots indicated temperature characteristic, tolerance, and decimal multiplier. The characteristic was black for ± 1000 ppm/ $^{\circ}\text{C}$, brown for ± 500 , red for ± 200 , orange for ± 100 , yellow for -20 to $+100$ ppm/ $^{\circ}\text{C}$, and green for 0 to $+70$ ppm/ $^{\circ}\text{C}$. A similar six-dot code by EIA had the top row as first, second and third significant digits and the bottom row as voltage rating (in hundreds of volts; no color indicated 500 volts), tolerance, and multiplier. A three-dot EIA code was used for 500 volt 20% tolerance capacitors, and the dots signified first and second significant digits and the multiplier. Such capacitors were common in vacuum tube equipment and in surplus for a generation after the war but are unavailable now.^[6]

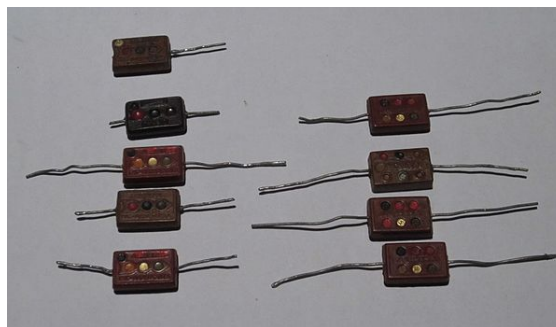

Postage-stamp mica capacitors marked with the EIA 3-dot and 6-dot color codes, giving capacitance value, tolerance, working voltage, and temperature characteristic. This style of capacitor was used in vacuum-tube equipment.

2.5 Mnemonics

Further information: [List of electronic color code mnemonics](#)

A useful mnemonic matches the first letter of the color code, by order of increasing magnitude. Here is one that includes tolerance codes gold, silver, and none:

- **B B ROY** Goes **B**ombay **V**ia **G**ateway **W**ith **G**enelia and **S**usanne.^[7]
- **B**ad **b**eer **r**ots **o**ur **y**oung **g**uts **b**ut **v**odka **g**oes **w**ell – **g**et some **n**ow.^[8]

The colors are sorted in the order of the visible light spectrum: red (2), orange (3), yellow (4), green (5), blue (6), violet (7). Black (0) has no energy, brown (1) has a little more, white (9) has everything and grey (8) is like white, but less intense.^[9]

2.6 Examples

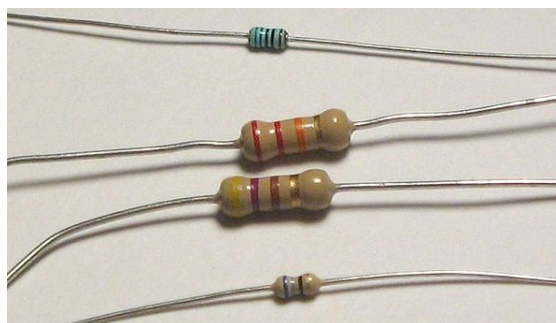

Color-coded resistors

From top to bottom:

- Green-Blue-Black-Black-Brown

- 560 ohms \pm 1%
- Red-Red-Orange-Gold
 - 22,000 ohms \pm 5%
- Yellow-Violet-Brown-Gold
 - 470 ohms \pm 5%
- Blue-Gray-Black-Gold
 - 68 ohms \pm 5%

The physical size of a resistor is indicative of the power it can dissipate, not of its resistance.

2.7 Transformer wiring color codes

Power transformers used in North American vacuum-tube equipment often were color-coded to identify the leads. Black was the primary connection, red secondary for the B+ (plate voltage), red with a yellow tracer was the center tap for the B+ full-wave rectifier winding, green or brown was the heater voltage for all tubes, yellow was the filament voltage for the rectifier tube (often a different voltage than other tube heaters). Two wires of each color were provided for each circuit, and phasing was not identified by the color code.

Audio transformers for vacuum tube equipment were coded blue for the finishing lead of the primary, red for the B+ lead of the primary, brown for a primary center tap, green for the finishing lead of the secondary, black for grid lead of the secondary, and yellow for a tapped secondary. Each lead had a different color since relative polarity or phase was more important for these transformers. Intermediate-frequency tuned transformers were coded blue and red for the primary and green and black for the secondary.^[6]

2.8 Other wiring codes

Wires may be color-coded to identify their function, voltage class, polarity, phase or to identify the circuit in which they are used. The insulation of the wire may be solidly colored, or where more combinations are needed, one or two tracer stripes may be added. Some wiring color codes are set by national regulations, but often a color code is specific to a manufacturer or industry.

Building wiring under the US National Electrical Code and the Canadian Electrical Code is identified by colors to show energized and neutral conductors, grounding conductors and to identify phases. Other color codes are used in the UK and other areas to identify building wiring or flexible cable wiring.

Thermocouple wires and extension cables are identified by color code for the type of thermocouple; interchanging thermocouples with unsuitable extension wires destroys the accuracy of the measurement.

Automotive wiring is color-coded but standards vary by manufacturer; differing SAE and DIN standards exist.

Modern personal computer peripheral cables and connectors are color-coded to simplify connection of speakers, microphones, mice, keyboards and other peripherals, usually according to the PC99 scheme.

A common convention for wiring systems in industrial buildings is; black jacket - AC less than 1000 volts, blue jacket - DC or communications, orange jacket - medium voltage 2300 or 4160 V, red jacket 13,800 volts or higher. Red-jacketed cable is also used for fire alarm wiring, but has a much different appearance, since it operates at relatively low voltages.

Local area network cables may also have jacket colors identifying, for example, process control network vs. office automation networks, or to identify redundant network connections, but these codes vary by organization and facility.

2.9 See also

- Color code
- Electrical wiring — AC power wiring inside buildings, including standard color codes

2.10 References

- [1] EIA
- [2] IEC 60062 Title: "Marking codes for resistors and capacitors" (IEC Webstore)
- [3] VR37 High ohmic/high voltage resistors. Vishay datasheet, VR37 High ohmic/high voltage resistors
- [4] NIC Components Corp. NZO series zero-ohm resistors.
- [5] *Reference Data for Radio Engineers*, Federal Telephone and Radio Corporation, 2nd edition, 1946 page 52
- [6] Tony Dorbuck (ed), *The Radio Amateur's Handbook Fifty Fifth (1978 edition)*, The American Radio Relay League, Connecticut 1977, no ISBN, Library of congress card no. 41-3345, pages 553–554
- [7] Color code Calc-Tutor for beginners
- [8] The Mnemonics Page - Dean Campbell, Bradley University Chemistry Department
- [9] Preston R. Clement and Walter Curtis Johnson (1960). *Electrical Engineering Science*. McGraw-Hill. p. 115.

2.11 External links

- [IEC 60062 \(IEC Webstore\)](#)
- [5-band Resistor Color Code Calculator](#)
- [Resistor color code calculator \(Used to explore E-ranges and color codes.\)](#)
- [Guide to SMD resistor codes, including alphanumeric codes](#)

Chapter 3

Surface-mount technology

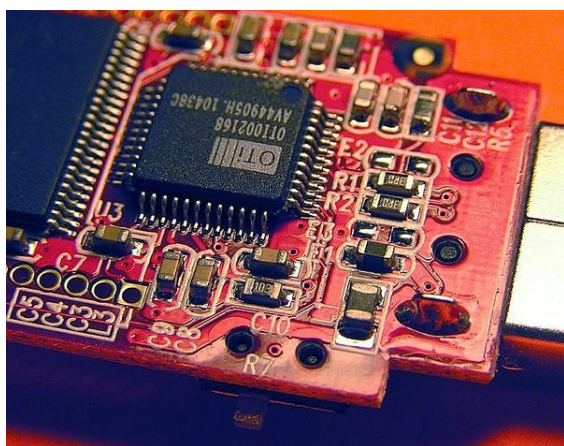

Surface-mount components on a USB flash drive's circuit board. The small rectangular chips with numbers are resistors, while the unmarked small rectangular chips are capacitors. The capacitors and resistors pictured are 0603 (1608 metric) package sizes, along with a very slightly larger 0805 (2012 metric) ferrite bead. Not shown here, even smaller chip capacitors are 0402 (1005 metric) and 0201 (0603 metric) sizes.

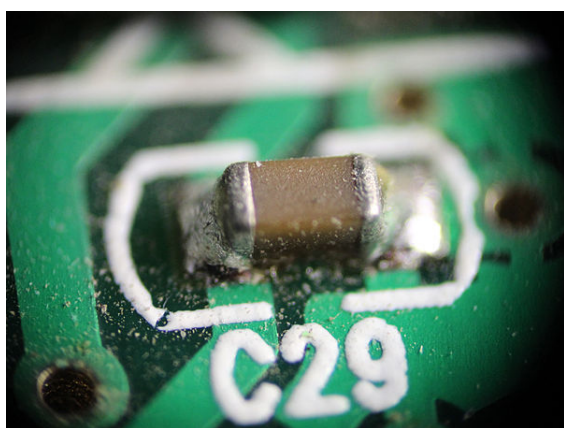

Surface-mount capacitor

Surface-mount technology (SMT) is a method for producing electronic circuits in which the components are mounted or placed directly onto the surface of printed circuit boards (PCBs). An electronic device so made is called a **surface-mount device (SMD)**. In the industry it has largely replaced the through-hole technology con-

struction method of fitting components with wire leads into holes in the circuit board. Both technologies can be used on the same board for components not suited to surface mounting such as large transformers and heat-sinked power semiconductors.

An SMT component is usually smaller than its through-hole counterpart because it has either smaller leads or no leads at all. It may have short pins or leads of various styles, flat contacts, a matrix of solder balls (BGAs), or terminations on the body of the component.

3.1 History

Surface mounting was originally called “planar mounting”.^[1]

Surface-mount technology was developed in the 1960s and became widely used in the late 1980s. Much of the pioneering work in this technology was by IBM. The design approach first demonstrated by IBM in 1960 in a small-scale computer was later applied in the Launch Vehicle Digital Computer used in the Instrument Unit that guided all Saturn IB and Saturn V vehicles.^[2] Components were mechanically redesigned to have small metal tabs or end caps that could be directly soldered to the surface of the PCB. Components became much smaller and component placement on both sides of a board became far more common with surface mounting than through-hole mounting, allowing much higher circuit densities. Often only the solder joints hold the parts to the board, in rare cases parts on the bottom or “second” side of the board may be secured with a dot of adhesive to keep components from dropping off inside reflow ovens if the part has a large size or weight. Adhesive is sometimes used to hold SMT components on the bottom side of a board if a wave soldering process is used to solder both SMT and through-hole components simultaneously. Alternatively, SMT and through-hole components can be soldered together without adhesive if the SMT parts are first reflow-soldered, then a selective solder mask is used to prevent the solder holding the parts in place from reflowing and the parts floating away during wave soldering. Surface mounting lends itself well to a high degree of automa-

tion, reducing labor cost and greatly increasing production rates. SMDs can be one-quarter to one-tenth the size and weight, and one-half to one-quarter the cost of equivalent through-hole parts.

3.2 Terms

Because “surface-mount” refers to a methodology of manufacturing, there are different terms used when referring to the different aspect of the method, which distinguishes for example the components, technique, and machines used in manufacturing. These terms are listed in the following table:

3.3 Assembly techniques



Assembly line with SMT placement machines

Where components are to be placed, the printed circuit board normally has flat, usually tin-lead, silver, or gold plated copper pads without holes, called *solder pads*. Solder paste, a sticky mixture of flux and tiny solder particles, is first applied to all the solder pads with a stainless steel or nickel stencil using a *screen printing* process. It can also be applied by a jet-printing mechanism, similar to an inkjet printer. After pasting, the boards then proceed to the *pick-and-place machines*, where they are placed on a conveyor belt. The components to be placed on the boards are usually delivered to the production line in either paper/plastic tapes wound on reels or plastic tubes. Some large integrated circuits are delivered in static-free trays. Numerical control pick-and-place machines remove the parts from the tapes, tubes or trays and place them on the PCB.

The boards are then conveyed into the *reflow soldering* oven. They first enter a pre-heat zone, where the temperature of the board and all the components is gradually, uniformly raised. The boards then enter a zone where the temperature is high enough to melt the solder particles in the solder paste, bonding the component leads to the pads on the circuit board. The surface tension of the molten

solder helps keep the components in place, and if the solder pad geometries are correctly designed, *surface tension* automatically aligns the components on their pads. There are a number of techniques for reflowing solder. One is to use *infrared lamps*; this is called infrared reflow. Another is to use a hot gas *convection*. Another technology which is becoming popular again is special *fluorocarbon* liquids with high boiling points which use a method called vapor phase reflow. Due to environmental concerns, this method was falling out of favor until lead-free legislation was introduced which requires tighter controls on soldering. Currently, at the end of 2008, convection soldering is the most popular reflow technology using either standard air or nitrogen gas. Each method has its advantages and disadvantages. With infrared reflow, the board designer must lay the board out so that short components don't fall into the shadows of tall components. Component location is less restricted if the designer knows that vapor phase reflow or convection soldering will be used in production. Following reflow soldering, certain irregular or heat-sensitive components may be installed and soldered by hand, or in large-scale automation, by focused infrared beam (FIB) or localized convection equipment.

If the circuit board is double-sided then this printing, placement, reflow process may be repeated using either solder paste or glue to hold the components in place. If a *wave soldering* process is used, then the parts must be glued to the board prior to processing to prevent them from floating off when the solder paste holding them in place is melted.

After soldering, the boards may be washed to remove flux residues and any stray solder balls that could short out closely spaced component leads. Rosin flux is removed with fluorocarbon solvents, high flash point hydrocarbon solvents, or low flash solvents e.g. limonene (derived from orange peels) which require extra rinsing or drying cycles. Water soluble fluxes are removed with *deionized water* and detergent, followed by an air blast to quickly remove residual water. However, most electronic assemblies are made using a “No-Clean” process where the flux residues are designed to be left on the circuit board [benign]. This saves the cost of cleaning, speeds up the manufacturing process, and reduces waste.

Certain manufacturing standards, such as those written by the *IPC - Association Connecting Electronics Industries* require cleaning regardless of the solder flux type used to ensure a thoroughly clean board. Even no-clean flux leaves a residue which, under IPC standards, must be removed. Proper cleaning removes all traces of solder flux, as well as dirt and other contaminants that may be invisible to the naked eye. However, while shops conforming to IPC standard are expected to adhere to the Association's rules on board condition, not all manufacturing facilities apply IPC standard, nor are they required to do so. Additionally, in some applications, such as low-end electronics, such stringent manufacturing methods are excessive both in expense and time required.

Finally, the boards are visually inspected for missing or misaligned components and solder bridging. If needed, they are sent to a *rework* station where a human operator repairs any errors. They are then usually sent to the testing stations (*in-circuit testing* and/or functional testing) to verify that they operate correctly.

3.4 Advantages

The main advantages of SMT over the older through-hole technique are:

- Smaller components. As of 2012 smallest was 0.4×0.2 mm (0.016×0.008 in: 01005). Expected to sample in 2013 are 0.25×0.125 mm (0.010×0.005 in, size not yet standardized)
- Much higher component density (components per unit area) and many more connections per component.
- Lower initial cost and time of setting up for production.
- Fewer holes need to be drilled.
- Simpler and faster automated assembly. Some placement machines are capable of placing more than 136,000 components per hour.
- Small errors in component placement are corrected automatically as the surface tension of molten solder pulls components into alignment with solder pads.
- Components can be placed on both sides of the circuit board.
- Lower resistance and inductance at the connection; consequently, fewer unwanted RF signal effects and better and more predictable high-frequency performance.
- Better mechanical performance under shake and vibration conditions.
- Many SMT parts cost less than equivalent through-hole parts.
- Better EMC performance (lower radiated emissions) due to the smaller radiation loop area (because of the smaller package) and the smaller lead inductance.^[3]

3.5 Disadvantages

- Manual prototype assembly or component-level repair is more difficult and requires skilled operators and more expensive tools, due to the small sizes and lead spacings of many SMDs.^[4]

- SMDs cannot be used directly with plug-in breadboards (a quick snap-and-play prototyping tool), requiring either a custom PCB for every prototype or the mounting of the SMD upon a pin-leaded carrier. For prototyping around a specific SMD component, a less-expensive *breakout board* may be used. Additionally, *stripboard* style protoboards can be used, some of which include pads for standard sized SMD components. For prototyping, "dead bug" breadboarding can be used.^[5]
- SMDs' solder connections may be damaged by potting compounds going through thermal cycling.
- Solder joint dimensions in SMT quickly become much smaller as advances are made toward ultra-fine pitch technology. The reliability of solder joints becomes more of a concern, as less and less solder is allowed for each joint. Voiding is a fault commonly associated with solder joints, especially when reflowing a solder paste in the SMT application. The presence of voids can deteriorate the joint strength and eventually lead to joint failure.^{[6][7]}
- SMT is unsuitable for large, high-power, or high-voltage parts, for example in power circuitry. It is common to combine SMT and through-hole construction, with transformers, heat-sinked power semiconductors, physically large capacitors, fuses, connectors, and so on mounted on one side of the PCB through holes.
- SMT is unsuitable as the sole attachment method for components that are subject to frequent mechanical stress, such as connectors that are used to interface with external devices that are frequently attached and detached.

3.6 Rework

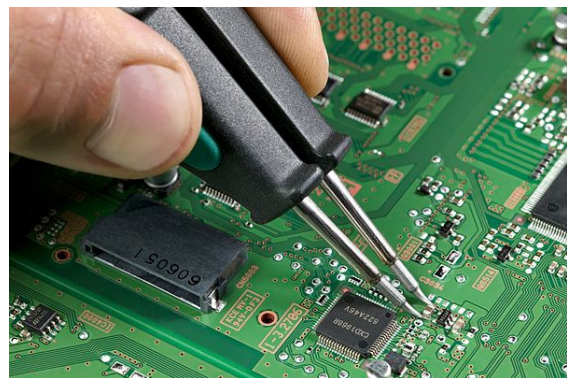

Removal of surface-mount device using soldering tweezers

Main article: [rework \(electronics\)](#)

Defective surface-mount components can be repaired by using **soldering irons** (for some connections), or using a non-contact rework system. In most cases a rework system is the better choice because SMD work with a soldering iron requires considerable skill and is not always feasible. There are essentially two non-contact soldering/desoldering methods: infrared soldering and soldering with hot gas.

3.6.1 Infrared

With infrared soldering, the energy for heating up the solder joint is transmitted by long- or short-wave infrared electromagnetic radiation.

Benefits:

- Easy setup
- No compressed air required
- No requirement for different nozzles for many component shapes and sizes, reducing cost and the need to change nozzles
- Fast reaction of infrared source (depends on system used)

Disadvantages:

- Central areas will be heated more than peripheral areas
- Temperature control is less precise, and there may be peaks
- Nearby components must be shielded from heat to prevent damage, which requires additional time for every board
- Surface temperature depends on the component's albedo: dark surfaces will be heated more than lighter surfaces
- The temperature additionally depends on the surface shape. Convective loss of energy will reduce the temperature of the component
- No reflow atmosphere possible

3.6.2 Hot gas

During hot gas soldering, the energy for heating up the solder joint is transmitted by a hot gas. This can be air or inert gas (nitrogen).

Benefits:

- Simulating reflow oven atmosphere

- Some systems allow switching between hot air and nitrogen
- Standard and component-specific nozzles allow high reliability and faster processing
- Allow reproducible soldering profiles
- Efficient heating, large amounts of heat can be transferred
- Even heating of the affected board area
- Temperature of the component will never exceed the adjusted gas temperature
- Rapid cooling after reflow, resulting in small-grained solder joints (depends on system used)

Disadvantages:

- Thermal capacity of the heat generator results in slow reaction whereby thermal profiles can be distorted (depends on system used)

Reworking usually corrects some type of error, either human- or machine-generated, and includes the following steps:

- Melt solder and remove component (s)
- Remove residual solder
- Print solder paste on PCB, directly or by dispensing
- Place new component and reflow.

Sometimes hundreds or thousands of the same part need to be repaired. Such errors, if due to assembly, are often caught during the process. However, a whole new level of rework arises when component failure is discovered too late, and perhaps unnoticed until the end user of the device being manufactured experiences it. Rework can also be used if products of sufficient value to justify it require revision or re-engineering, perhaps to change a single firmware-based component. Reworking in large volume requires an operation designed for that purpose.

3.7 Packages

Main article: [Chip carrier](#)

Surface-mount components are usually smaller than their counterparts with leads, and are designed to be handled by machines rather than by humans. The electronics industry has standardized package shapes and sizes (the leading standardisation body is JEDEC). These include:

The codes given in the chart below usually tell the length and width of the components in tenths of millimeters or

hundredths of inches. For example, a metric 2520 component is 2.5 mm by 2.0 mm which corresponds roughly to .10 inches by .08 inches (hence, imperial size is 1008). Exceptions occur for imperial in the two smallest rectangular passive sizes. The metric codes still represent the dimensions in mm, even though the imperial size codes are no longer aligned. Problematically, some manufacturers are developing metric 0201 components with dimensions of 0.25 mm × 0.125 mm (0.0098 in × 0.0049 in),^[8] but the imperial 01005 name is already being used for the 0.4 mm × 0.2 mm (0.0157 in × 0.0079 in) package.

<i>comparison</i>	Metric code	Imperial code	<i>comparison</i>
0.1x0.1 mm	0402	01005	0.01x0.01 in (10x10 mils)
	0603	0201	
	1005	0402	
	1608	0603	
1x1 mm	2012	0805	0.1x0.1 in (100x100 mils)
	2520	1008	
	3216	1206	
	3225	1210	
	4516	1806	
	4532	1812	
1x1 cm	5025	2010	0.5x0.5 in (500x500 mils)
	6332	2512	
	Actual size		

Example of component sizes, metric and imperial codes and comparison included

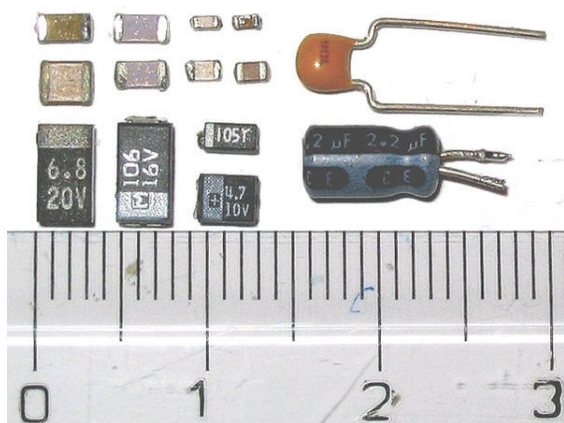

SMD capacitors (on the left) with two through-hole capacitors (on the right)

• **Two-terminal packages**

- Rectangular passive components (mostly resistors and capacitors):

- 01005 (0402 metric): 0.4 mm × 0.2 mm (0.0157 in × 0.0079 in). Typical power rating for resistors = 0.031 watt^[9]
- 0201 (0603 metric): 0.6 mm × 0.3 mm (0.024 in × 0.012 in). Typical power rating for resistors = 0.05 watt^[9]
- 0402 (1005 metric): 1.0 mm × 0.5 mm (0.039 in × 0.020 in). Typical power rating for resistors = 0.1^[9] or 0.062 watt^[10]
- 0603 (1608 metric): 1.6 mm × 0.8 mm (0.063 in × 0.031 in). Typical power rating for resistors = 0.1 watt^[9]
- 0805 (2012 metric): 2.0 mm × 1.25 mm (0.079 in × 0.049 in). Typical power rating for resistors = 0.125 watt^[9]
- 1008 (2520 metric): 2.5 mm × 2.0 mm (0.098 in × 0.079 in). Typical inductor and ferrite bead package^[11]
- 1206 (3216 metric): 3.2 mm × 1.6 mm (0.126 in × 0.063 in). Typical power rating for resistors = 0.25 watt^[9]
- 1210 (3225 metric): 3.2 mm × 2.5 mm (0.126 in × 0.098 in). Typical power rating for resistors = 0.5 watt^[9]
- 1806 (4516 metric): 4.5 mm × 1.6 mm (0.177 in × 0.063 in)^[12]
- 1812 (4532 metric): 4.5 mm × 3.2 mm (0.18 in × 0.13 in). Typical power rating for resistors = 0.75 watt^[9]
- 2010 (5025 metric): 5.0 mm × 2.5 mm (0.197 in × 0.098 in). Typical power rating for resistors = 0.75 watt^[9]
- 2512 (6332 metric): 6.3 mm × 3.2 mm (0.25 in × 0.13 in). Typical power rating for resistors = 1 watt^[9]
- 2920: 7.4 mm × 5.1 mm (0.29 in × 0.20 in)^[13]
- Tantalum capacitors length (typ.) × width (typ.) × height (max.):^{[14][15]}
 - EIA 2012-12 (Kemet R, AVX R): 2.0 mm × 1.3 mm × 1.2 mm
 - EIA 3216-10 (Kemet I, AVX K): 3.2 mm × 1.6 mm × 1.0 mm
 - EIA 3216-12 (Kemet S, AVX S): 3.2 mm × 1.6 mm × 1.2 mm
 - EIA 3216-18 (Kemet A, AVX A): 3.2 mm × 1.6 mm × 1.8 mm
 - EIA 3528-12 (Kemet T, AVX T): 3.5 mm × 2.8 mm × 1.2 mm
 - EIA 3528-21 (Kemet B, AVX B): 3.5 mm × 2.8 mm × 2.1 mm
 - EIA 6032-15 (Kemet U, AVX W): 6.0 mm × 3.2 mm × 1.5 mm
 - EIA 6032-28 (Kemet C, AVX C): 6.0 mm × 3.2 mm × 2.8 mm

- EIA 7260-38 (Kemet E, AVX V): 7.3 mm × 6.0 mm × 3.8 mm
- EIA 7343-20 (Kemet V, AVX Y): 7.3 mm × 4.3 mm × 2.0 mm
- EIA 7343-31 (Kemet D, AVX D): 7.3 mm × 4.3 mm × 3.1 mm
- EIA 7343-43 (Kemet X, AVX E): 7.3 mm × 4.3 mm × 4.3 mm
- Aluminium capacitors:^{[16][17][18]}
 - (Panasonic / CDE A, Chemi-Con B): 3.3 mm × 3.3 mm
 - (Panasonic B, Chemi-Con D): 4.3 mm × 4.3 mm
 - (Panasonic C, Chemi-Con E): 5.3 mm × 5.3 mm
 - (Panasonic D, Chemi-Con F): 6.6 mm × 6.6 mm
 - (Panasonic E/F, Chemi-Con H): 8.3 mm × 8.3 mm
 - (Panasonic G, Chemi-Con J): 10.3 mm × 10.3 mm
 - (Chemi-Con K): 13.0 mm × 13.0 mm
 - (Panasonic H): 13.5 mm × 13.5 mm
 - (Panasonic J, Chemi-Con L): 17.0 mm × 17.0 mm
 - (Panasonic K, Chemi-Con M): 19.0 mm × 19.0 mm
- SOD: Small Outline Diode
 - SOD-723: 1.4 × 0.6 × 0.59 mm^[19]
 - SOD-523 (SC-79): 1.25 × 0.85 × 0.65 mm^[20]
 - SOD-323 (SC-90): 1.7 × 1.25 × 0.95 mm^[21]
 - SOD-128: 5 × 2.7 × 1.1 mm^[22]
 - SOD-123: 3.68 × 1.17 × 1.60 mm^[23]
 - SOD-80C: 3.50 × 1.50 × More info^[24]
- MELF (Metal Electrode Leadless Face): mostly resistors and diodes; barrel shaped components, dimensions do not match those of rectangular references for identical codes.
 - MicroMelf (MMU) Size 0102: length: 2.2 mm, diam.: 1.1 mm. Typical rating for resistors = 0.2 to 0.3 watt / 150 V^[25]
 - MiniMelf (MMA) Size 0204: length: 3.6 mm, diam.: 1.4 mm. Typical rating for resistors = 0.25 to 0.4 watt / 200 V^[25]
 - Melf (MMB) Size 0207: length: 5.8 mm, diam.: 2.2 mm. Typical rating for resistors = 0.4 to 1 watt / 300 V^[25]
- DO-214
 - DO-214AA (SMB): 5.30 × 3.60 × 2.25 mm (Dimension include leads)^[26]
 - DO-214AB (SMC): 7.95 × 5.90 × 2.25 mm (Dimension include leads)^[27]
 - DO-214AC (SMA): 5.20 × 2.60 × 2.15 mm (Dimension include leads)^[28]
- Three-terminal packages
 - SOT: Small Outline Transistor, three terminals
 - SOT-223: 6.7 mm × 3.7 mm × 1.8 mm body: four terminals, one of which is a large heat-transfer pad^[29]
 - SOT-89: 4.5 mm × 2.5 mm × 1.5 mm body: four terminals, center pin is connected to a large heat-transfer pad^[30]
 - SOT-23 (SC-59, TO-236-3): 2.9 mm × 1.3/1.75 mm × 1.3 mm body: three terminals for a transistor^[31]
 - SOT-323 (SC-70): 2 mm × 1.25 mm × 0.95 mm body: three terminals^[32]
 - SOT-416 (SC-75): 1.6 mm × 0.8 mm × 0.8 mm body: three terminals^[33]
 - SOT-663: 1.6 mm × 1.6 mm × 0.55 mm body: three terminals^[34]
 - SOT-723: 1.2 mm × 0.8 mm × 0.5 mm body: three terminals: flat lead^[35]
 - SOT-883 (SC-101): 1 mm × 0.6 mm × 0.5 mm body: three terminals: leadless^[36]
 - DPAK (TO-252, SOT-428): Discrete Packaging. Developed by Motorola to house higher powered devices. Comes in three- or five-terminal versions^[37]
 - D2PAK (TO-263, SOT-404): bigger than the DPAK; basically a surface mount equivalent of the TO220 through-hole package. Comes in 3, 5, 6, 7, 8 or 9-terminal versions^[38]
 - D3PAK (TO-268): even larger than D2PAK^[39]
- Five- and six-terminal packages
 - SOT: small-outline transistor, with more than three terminals
 - SOT-23-5 (SOT-25, SC-74A): 2.9 mm × 1.3/1.75 mm × 1.3 mm body: five terminals^[40]
 - SOT-23-6 (SOT-26, SC-74): 2.9 mm × 1.3/1.75 mm × 1.3 mm body: six terminals^[41]
 - SOT-23-8 (SOT-28): 2.9 mm × 1.3/1.75 mm × 1.3 mm body: eight terminals^[42]
 - SOT-353 (SC-88A): 2 mm × 1.25 mm × 0.95 mm body: five terminals^[43]
 - SOT-363 (SC-88, SC-70-6): 2 mm × 1.25 mm × 0.95 mm body: six terminals^[44]

- SOT-563: 1.6 mm × 1.2 mm × 0.6 mm body: six terminals ^[45]
- SOT-665: 1.6 mm × 1.6 mm × 0.55 mm body: six terminals ^[46]
- SOT-666: 1.6 mm × 1.6 mm × 0.55 mm body: six terminals ^[47]
- SOT-886: 1.5 mm × 1.05 mm × 0.5 mm body: six terminals: leadless
- SOT-886: 1 mm × 1.45 mm × 0.5 mm body: six terminals: leadless ^[48]
- SOT-891: 1.05 mm × 1.05 mm × 0.5 mm body: five terminals: leadless
- SOT-953: 1 mm × 1 mm × 0.5 mm body: five terminals
- SOT-963: 1 mm × 1 mm × 0.5 mm body: six terminals
- SOT-1115: 0.9 mm × 1 mm × 0.35 mm body: six terminals: leadless ^[49]
- SOT-1202: 1 mm × 1 mm × 0.35 mm body: six terminals: leadless ^[50]

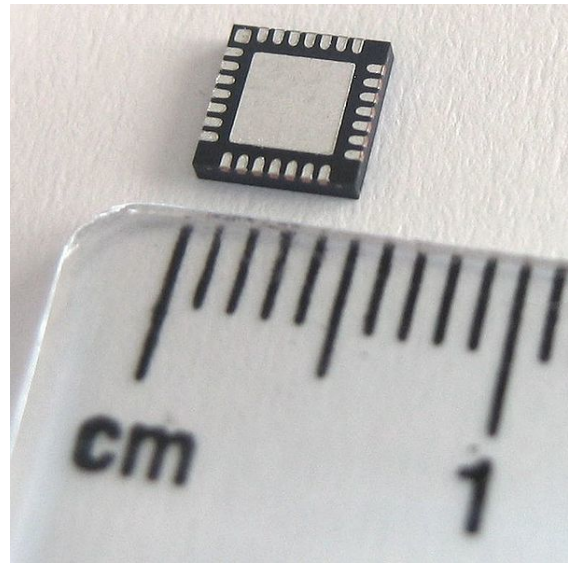

MLP package 28-pin chip, upside down to show contacts

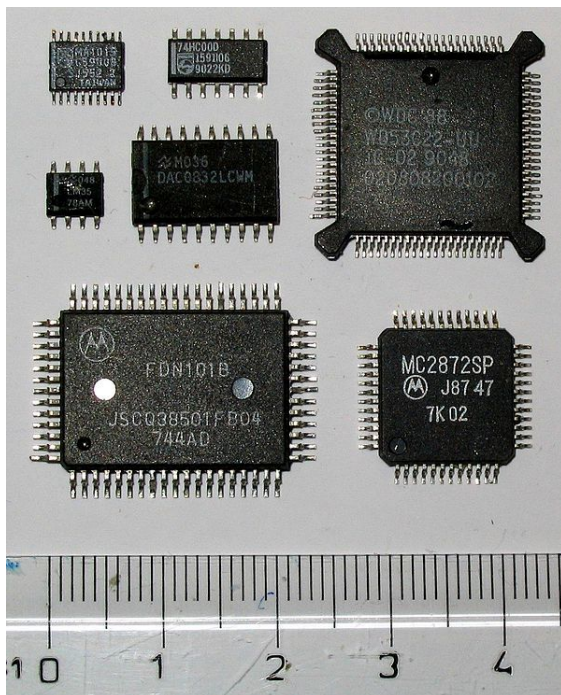

Various SMD chips, desoldered

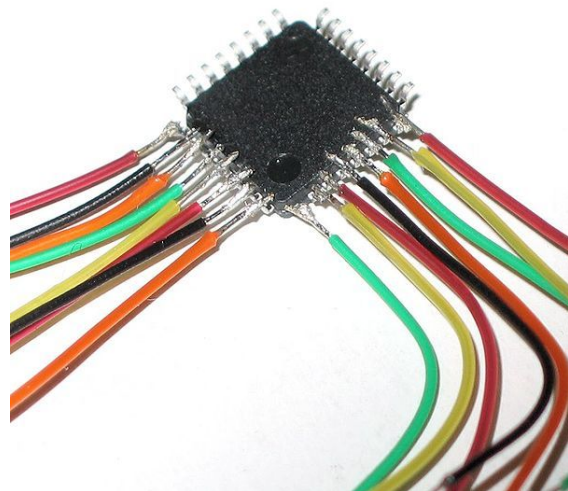

32-pin MQFP chip with manually soldered wires attached for prototyping. The same effect can be achieved using commercially available breakout boards

- **Packages with more than six terminals**^[51]

- Dual-in-line

- flatpack was one of the earliest surface-mounted packages.
- SOIC: (Small-Outline Integrated Circuit), dual-in-line, 8 or more pins, gull-wing lead form, pin spacing 1.27 mm
- SOJ: Small-Outline Package, J-Leaded, the same as SOIC except J-leaded ^[52]

- TSOP: Thin Small-Outline Package, thinner than SOIC with smaller pin spacing of 0.5 mm
- SSOP: Shrink Small-Outline Package, pin spacing of 0.65 mm, sometimes 0.635 mm or in some cases 0.8 mm
- TSSOP: Thin Shrink Small-Outline package.
- QSOP: Quarter-Size Small-Outline package, with pin spacing of 0.635 mm
- VSOP: Very Small Outline Package, even smaller than QSOP; 0.4, 0.5 mm or 0.65 mm pin spacing
- DFN: Dual Flat No-lead, smaller foot-

- print than leaded equivalent
- Quad-in-line
 - **PLCC**: Plastic Leaded Chip Carrier, square, J-lead, pin spacing 1.27 mm
 - **QFP**: Quad Flat Package, various sizes, with pins on all four sides
 - **LQFP**: Low-profile Quad Flat Package, 1.4 mm high, varying sized and pins on all four sides
 - **PQFP**: Plastic Quad Flat-Pack, a square with pins on all four sides, 44 or more pins
 - **CQFP**: Ceramic Quad Flat-Pack, similar to PQFP
 - **MQFP**: Metric Quad Flat Pack, a QFP package with metric pin distribution
 - **TQFP**: Thin Quad Flat Pack, a thinner version of PQFP
 - **QFN**: Quad Flat No-lead, smaller footprint than leaded equivalent
 - **LCC**: Leadless Chip Carrier, contacts are recessed vertically to “wick-in” solder. Common in aviation electronics because of robustness to mechanical vibration.
 - **MLP (MLF)**: Micro Leadframe Package (Micro Lead-Frame package) with a 0.5 mm contact pitch, no leads (same as QFN) ^[53]
 - **PQFN**: Power Quad Flat No-lead, with exposed die-pad[s] for heatsinking
 - Grid arrays
 - **PGA**: Pin grid array.
 - **BGA**: Ball Grid Array, with a square or rectangular array of solder balls on one surface, ball spacing typically 1.27 mm
 - **LGA**: An array of bare lands only. Similar to in appearance to QFN, but mating is by spring pins within a socket rather than solder.
 - **FBGA**: Fine pitch Ball Grid Array, with a square or rectangular array of solder balls on one surface
 - **LFBGA**: Low profile Fine pitch Ball Grid Array, with a square or rectangular array of solder balls on one surface, ball spacing typically 0.8 mm
 - **TFBGA**: Thin Fine pitch Ball Grid Array, with a square or rectangular array of solder balls on one surface, ball spacing typically 0.5 mm
 - **CGA**: Column Grid Array, circuit package in which the input and output points are high temperature solder cylinders or columns arranged in a grid pattern.
 - **CCGA**: Ceramic Column Grid Array, circuit package in which the input and output points are high temperature solder cylinders or columns arranged in a grid pattern. The body of the component is ceramic.
 - **μBGA**: micro-BGA, with ball spacing less than 1 mm
 - **LLP**: Lead Less Package, a package with metric pin distribution (0.5 mm pitch).
 - Non-packaged devices (although surface-mount, these devices require specific process for assembly):
 - **COB**: Chip-On-Board; a bare silicon chip, that is usually an integrated circuit, is supplied without a package (usually a lead frame overmolded with epoxy) and is attached, often with epoxy, directly to a circuit board. The chip is then wire bonded and protected from mechanical damage and contamination by an epoxy “glob-top”.
 - **COF**: Chip-On-Flex; a variation of COB, where a chip is mounted directly to a flex circuit.
 - **COG**: Chip-On-Glass; a variation of COB, where a chip, typically a Liquid crystal display (LCD) controller, is mounted directly on glass:.

There are often subtle variations in package details from manufacturer to manufacturer, and even though standard designations are used, designers need to confirm dimensions when laying out printed circuit boards.

3.8 Identification

3.8.1 Resistors

For 5% precision SMD resistors usually are marked with their resistance values using three digits, two significant digits and a multiplier digit. These are quite often white lettering on a black background, but other colored backgrounds and lettering can be used.

The black or colored coating is usually only on one face of the device, the sides and other face simply being the uncoated, usually white ceramic substrate. The coated surface, with the resistive element beneath is normally positioned face up when the device is soldered to the board although they can rarely be seen mounted with the uncoated underside face up, whereby the resistance value code is not visible.

For 1% precision SMD resistors, the code is used, as three digits would otherwise not convey enough information.

This code consists of two digits and a letter: the digits denote the value's position in the E96 sequence, while the letter indicates the multiplier.

Typical examples of resistance codes

$$102 = 10\ 00 = 1,000\ \Omega = 1\ \text{k}\Omega$$

$$0R2 = 0.2\ \Omega$$

$$684 = 68\ 0000 = 680,000\ \Omega = 680\ \text{k}\Omega$$

$$68X = 499 \times 0.1 = 49.9\ \Omega$$

There is an online tool to translate codes to resistance values. Resistors are made in several types; a common types uses a ceramic substrate. Resistance values are available in several tolerances defined in EIA Decade Values Table :

E3 50% tolerance (no longer used)

E6 20% tolerance (now seldom used)

E12 10% tolerance

E24 5% tolerance

E48 2% tolerance

E96 1% tolerance

E192 0.5, 0.25, 0.1% and higher tolerances

3.8.2 Capacitors

Non electrolytic capacitors are usually unmarked and the only reliable method of determining their value is removal from the circuit and subsequent measurement with a capacitance meter or impedance bridge. The materials used to fabricate the capacitors, such as Nickel Tantalate, possess different colours and these can give an approximate idea of the capacitance of the component.

Light grey body colour indicates a capacitance which is generally less than 100 pF.

Medium Grey colour indicates a capacitance anywhere from 10 pF to 10 nF.

Light brown colour indicates a capacitance in a range from 1 nF to 100 nF.

Medium brown colour indicates a capacitance in a range from 10 nF to 1 μ F.

Dark brown colour indicates a capacitance from 100 nF to 10 μ F.

Dark grey colour indicates a capacitance in the μ F range, generally 0.5 to 50 μ F, or the device may be an inductor and the dark grey is the color of the ferrite bead. (An inductor will measure a low resistance to a multimeter on the resistance range whereas a capacitor, *out of the circuit*, will measure a near infinite resistance.)

Generally physical size is proportional to capacitance and voltage² for the same dielectric. For example, a 100 nF 50 V capacitor may come in the same package as a 10 nF 150 V device.

SMD (non electrolytic) capacitors, which are usually monolithic ceramic capacitors, exhibit the same body color on all four faces not covered by the end caps.

SMD electrolytic capacitors, usually tantalum capacitors, and film capacitors are marked like resistors, with two significant figures and a multiplier in units of pico Farads or pF, (10^{-12} Farad.)

Examples

$$104 = 100\ \text{nF} = 100,000\ \text{pF}$$

$$226 = 22\ \mu\text{F} = 22,000,000\ \text{pF}$$

The electrolytic capacitors are usually encapsulated in black or beige epoxy resin with flat metal connecting strips bent underneath. Some film or tantalum electrolytic types are unmarked and possess red, orange or blue body colors with complete end caps, not metal strips.

3.8.3 Inductors

Due to the small dimensions of SMDs, SMT inductors are limited to values of less than about 10 mH. Smaller inductance with moderately high current ratings are usually of the ferrite bead type. They are simply a metal conductor looped through a ferrite bead and almost the same as their through-hole versions but possess SMD end caps rather than leads. They appear dark grey and are magnetic, unlike capacitors with a similar dark grey appearance. These ferrite bead type are limited to small values in the nH (nano Henry), range and are often used as power supply rail decouplers or in high frequency parts of a circuit. Larger inductors and transformers may of course be through-hole mounted on the same board.

SMT inductors with larger inductance values often have turns of wire or flat strap around the body or embedded in clear epoxy, allowing the wire or strap to be seen. Sometimes a ferrite core is present also. These higher inductance types are often limited to small current ratings, although some of the flat strap types can handle a few amps.

As with capacitors, component values and identifiers are not usually marked on the component itself; if not documented or printed on the PCB, measurement, usually removed from the circuit, is the only way of determining them.

3.8.4 Discrete semiconductors

Discrete semiconductors, such as transistors, diodes and F.E.T.s are often marked with a two- or three-symbol

code in which the same code marked on different packages or on devices made by different manufacturers can translate to different devices.

Many of these codes, used because the devices are too small to be marked with more traditional numbers used on through-hole equivalent devices, correlate to more familiar traditional part numbers when a correlation list is consulted.

GM4PMK in the United Kingdom has prepared a correlation list, and a similar .pdf list is also available, although these lists are not complete.

3.8.5 Integrated circuits

Generally, integrated circuit packages are large enough to be imprinted with the complete part number which includes the manufacturer's specific prefix, or a significant segment of the part number and the manufacturer's name or logo.

Examples of manufacturers' specific prefixes:

- Philips HEF4066 or Motorola MC14066. (a 4066 Quad Analog Switch.)
- Fujitsu Electric FA5502. (a 5502M Boost Architecture Power factor correction controller.)

3.9 See also

- Board to board connectors
- Chip carrier
- Electronics
- Electronics Manufacturing Services
- List of electronics package dimensions
- Plastic leaded chip carrier
- Point-to-point construction
- Printed circuit board
- RoHS
- SMT placement equipment
- Through-hole technology
- Wire wrap

3.10 References

- [1] "Surface mount technology status" (PDF). Retrieved 2013-07-18.
- [2] "High-resolution photos of components/PCBs". Spaceaholic.com. Retrieved 2011-07-07.
- [3] Mark I. Montrose, *EMC and the Printed Circuit Board: Design, Theory, and Layout Made Simple*, John Wiley and Sons, 1999, ISBN 0-7803-4703-X, p64.
- [4] Mike Judd, Keith Brindley (ed) *Soldering in electronics Assembly Second Edition* Elsevier, 1999 978-0-7506-3545-5 p.128
- [5] Linear technologies AN47. Dead-bug breadboards with ground plane, and other prototyping techniques for high frequencies, illustrated in Figures F1 to F24, from p.AN47-98. There is information on breadboarding on pages AN47-26 to AN47-29.
- [6] "Voiding Mechanisms in SMT". Indium.com. Retrieved 2011-07-07.
- [7] DerMarderosian, Aaron (1983). *The Effects of Entrapped Bubbles in Solder for The Attachment of Leadless Ceramic Chip Carriers*. Reliability Physics Symposium. pp. 235–241. ISSN 0735-0791.
- [8] "Murata's world's Smallest Monolithic Ceramic Capacitor - 0201 size (0.25 mm x 0.125 mm) | 2012 | Murata Manufacturing Co., Ltd". Murata.com. 2012-09-05. Retrieved 2013-07-18.
- [9] Panasonic, "Thick Film Chip Resistors" (PDF). Retrieved 2012-03-07.
- [10] electronic sensor + resistor GmbH, "SMD Resistors" (PDF). Retrieved 2012-03-07.
- [11] Kemet, "Surface Mount Ferrite Products – Inductors & Ferrite Beads" (PDF). Retrieved 2012-03-07.
- [12] Murata, "EMIFIL EMI Suppression Filters" (PDF). Retrieved 2012-03-07.
- [13] Littelfuse, "POLYFUSE Resettable Fuses" (PDF). Retrieved 2012-03-07.
- [14] AVX, "TLJ Series Tantalum Solid Electrolytic Chip Capacitors" (PDF). Retrieved 2012-03-06.
- [15] KEMET, "Tantalum Surface Mount Capacitors – Standard Tantalum" (PDF). Retrieved 2012-03-06.
- [16] Panasonic, "FK Series, SMT Aluminium Electrolytic Capacitors" (PDF). Retrieved 2011-07-07.
- [17] Cornell Dubilier, "Application Guide – Aluminium SMT Capacitors" (PDF). Retrieved 2012-02-05.
- [18] Nippon Chemi-Con, "MVA Series Surface Mount Aluminium Capacitors" (PDF). Retrieved 2012-02-05.
- [19] "CDSP400-G". digikey.com. Retrieved 2013-07-18.
- [20] "SOD523". nxp.com. Retrieved 2013-11-04.

- [21] http://www.diodes.com/zetex/_pdfs/3.0/pack/SOD323.pdf
- [22] “sod128”. nxp.com. Retrieved 2013-07-18.
- [23] “mmsz4678t1-d”. .siliconexpert.com. Retrieved 2013-07-18.
- [24] “SOD80C_PKG_DRAWING.XLS” (PDF). Retrieved 2011-07-07.
- [25] Vishay, “Professional MELF Resistors” (PDF). vishay.com. Retrieved 2012-03-07.
- [26] <http://www.diodes.com/datasheets/ap02002.pdf#page=48>. Missing or empty `title=` (help)
- [27] <http://www.diodes.com/datasheets/ap02002.pdf#page=49>. Missing or empty `title=` (help)
- [28] <http://www.diodes.com/datasheets/ap02002.pdf#page=48>. Missing or empty `title=` (help)
- [29] “MA04A”. Fairchild Semiconductor. Retrieved 2013-07-18.
- [30]
- [31] “P3.064”. Intersil. Retrieved 2013-07-18.
- [32] “SOT323”. nxp.com. Retrieved 2013-07-18.
- [33] “sot416”. nxp.com. Retrieved 2013-07-18.
- [34] “sot663_po”. nxp.com. Retrieved 2013-07-18.
- [35] “631AA”. onsemi.com. Retrieved 2013-07-18.
- [36] “sot883_po”. nxp.com. Retrieved 2013-07-18.
- [37] http://www.diodes.com/zetex/_pdfs/3.0/pack/DPAK.pdf
- [38] “Packaging & Ordering Info for Fairchild’s TO-263/D2DPAK”. Fairchildsemi.com. Retrieved 2012-03-04.
- [39] “TO 268 diagram”. Fairchild Semiconductor. Retrieved 2013-07-18.
- [40] “P5.064”. intersil.com. Retrieved 2013-07-18.
- [41] <http://www.intersil.com/data/pk/P6.064.pdf>
- [42] “P8.064”. intersil.com. Retrieved 2013-07-18.
- [43] “sot353_po”. nxp.com. Retrieved 2013-07-18.
- [44] “sot363_po”. nxp.com. Retrieved 2013-07-18.
- [45] “SOT-563PD”. centralsemi.com. Retrieved 2013-07-18.
- [46] “sot665_po”. nxp.com. Retrieved 2013-07-18.
- [47] “sot666_po”. nxp.com. Retrieved 2013-07-18.
- [48] “sot886_po”. nxp.com. Retrieved 2013-07-18.
- [49] “sot1115_po”. nxp.com. Retrieved 2013-07-18.
- [50] “sot1202_po”. nxp.com. Retrieved 2013-07-18.
- [51] Drawings of most of the following packages can be found on Intersil’s site)
- [52] “IC Package Types or Outlines”. Siliconfareast.com. Retrieved 2013-07-18.
- [53] “mlp_dd”. carsem.com. Retrieved 2013-07-18.

3.11 Further reading

- SMT magazine, PDF back issues
- PCB Design magazine, PDF back issues

3.12 External links

- International Microelectronics And Packaging Society
- Surface Mount Technology Association (SMTA)
- IC Package types
- Calculator for the SMD codes for resistors
- Surface Mount Forums

Chapter 4

Operational amplifier

An **operational amplifier** (op-amp) is a DC-coupled high-gain electronic voltage amplifier with a differential input and, usually, a single-ended output.^[1] In this configuration, an op-amp produces an output potential (relative to circuit ground) that is typically hundreds of thousands of times larger than the potential difference between its input terminals.^[2]

Operational amplifiers had their origins in **analog computers**, where they were used to do mathematical operations in many linear, non-linear and frequency-dependent circuits. Characteristics of a circuit using an op-amp are set by external components with little dependence on temperature changes or manufacturing variations in the op-amp itself, which makes op-amps popular building blocks for **circuit design**.

Op-amps are among the most widely used electronic devices today, being used in a vast array of consumer, industrial, and scientific devices. Many standard IC op-amps cost only a few cents in moderate production volume; however some integrated or hybrid operational amplifiers with special performance specifications may cost over \$100 US in small quantities.^[3] Op-amps may be packaged as components, or used as elements of more complex integrated circuits.

The op-amp is one type of **differential amplifier**. Other types of differential amplifier include the **fully differential amplifier** (similar to the op-amp, but with two outputs), the **instrumentation amplifier** (usually built from three op-amps), the **isolation amplifier** (similar to the instrumentation amplifier, but with tolerance to **common-mode voltages** that would destroy an ordinary op-amp), and **negative feedback amplifier** (usually built from one or more op-amps and a resistive feedback network).

4.1 Operation

The amplifier's differential inputs consist of a non-inverting input (+) with voltage V_+ and an inverting input (-) with voltage V_- ; ideally the op-amp amplifies only the difference in voltage between the two, which is called the *differential input voltage*. The output voltage of the op-amp V_{out} is given by the equation:

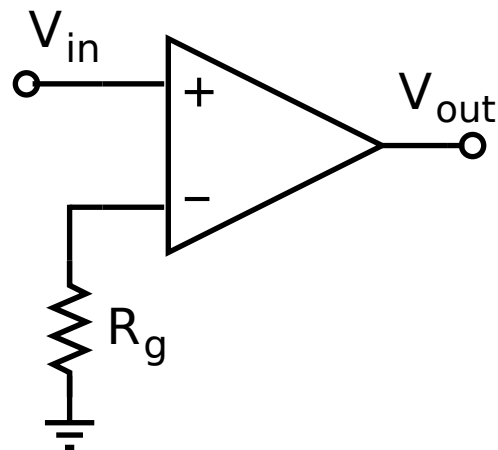

An op-amp without negative feedback (a comparator)

$$V_{out} = A_{OL} (V_+ - V_-)$$

where AOL is the **open-loop gain** of the amplifier (the term “open-loop” refers to the absence of a feedback loop from the output to the input).

4.1.1 Open loop amplifier

The magnitude of AOL is typically very large—100,000 or more for integrated circuit op-amps—and therefore even a quite small difference between V_+ and V_- drives the amplifier output nearly to the supply voltage. Situations in which the output voltage is equal to or greater than the supply voltage are referred to as *saturation* of the amplifier. The magnitude of AOL is not well controlled by the manufacturing process, and so it is impractical to use an operational amplifier as a stand-alone **differential amplifier**.

Without **negative feedback**, and perhaps with **positive feedback for regeneration**, an op-amp acts as a **comparator**. If the inverting input is held at ground (0 V) directly or by a resistor R_g , and the input voltage V_{in}

applied to the non-inverting input is positive, the output will be maximum positive; if V_{in} is negative, the output will be maximum negative. Since there is no feedback from the output to either input, this is an *open loop* circuit acting as a *comparator*.

4.1.2 Closed loop

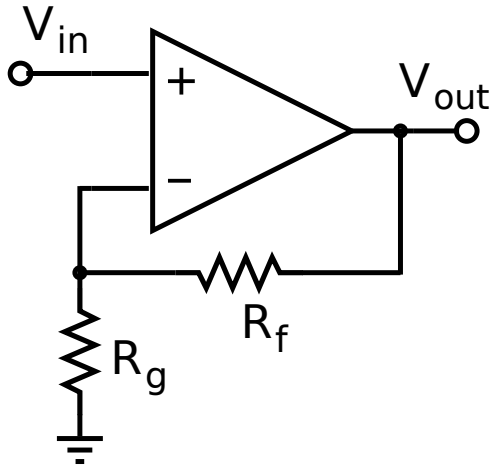

An op-amp with negative feedback (a non-inverting amplifier)

If predictable operation is desired, negative feedback is used, by applying a portion of the output voltage to the inverting input. The *closed loop* feedback greatly reduces the gain of the circuit. When negative feedback is used, the circuit's overall gain and response becomes determined mostly by the feedback network, rather than by the op-amp characteristics. If the feedback network is made of components with values small relative to the op-amp's input impedance, the value of the op-amp's open loop response AOL does not seriously affect the circuit's performance. The response of the op-amp circuit with its input, output, and feedback circuits to an input is characterized mathematically by a *transfer function*; designing an op-amp circuit to have a desired transfer function is in the realm of *electrical engineering*. The transfer functions are important in most applications of op-amps, such as in *analog computers*. High input impedance at the input terminals and low output impedance at the output terminal(s) are particularly useful features of an op-amp.

In the non-inverting amplifier on the right, the presence of negative feedback via the voltage divider R_f , R_g determines the *closed-loop gain* $ACL = V_{out} / V_{in}$. Equilibrium will be established when V_{out} is just sufficient to "reach around and pull" the inverting input to the same voltage as V_{in} . The voltage gain of the entire circuit is thus $1 + R_f/R_g$. As a simple example, if $V_{in} = 1$ V and $R_f = R_g$, V_{out} will be 2 V, exactly the amount required to keep V_- at 1 V. Because of the feedback provided by the R_f , R_g

network, this is a *closed loop* circuit.

Another way to analyze this circuit proceeds by making the following (usually valid) assumptions:^[4]

- When an op-amp operates in linear (i.e., not saturated) mode, the difference in voltage between the non-inverting (+) pin and the inverting (-) pin is negligibly small.
- The input impedance between (+) and (-) pins is much larger than other resistances in the circuit.

The input signal V_{in} appears at both (+) and (-) pins, resulting in a current i through R_g equal to V_{in}/R_g .

$$i = \frac{V_{in}}{R_g}$$

Since Kirchhoff's current law states that the same current must leave a node as enter it, and since the impedance into the (-) pin is near infinity, we can assume practically all of the same current i flows through R_f , creating an output voltage

$$V_{out} = V_{in} + i \times R_f = V_{in} + \left(\frac{V_{in}}{R_g} \times R_f \right) = V_{in} + \frac{V_{in} \times R_f}{R_g} = V_{in} \left(1 + \frac{R_f}{R_g} \right)$$

By combining terms, we determine the closed-loop gain ACL:

$$ACL = \frac{V_{out}}{V_{in}} = 1 + \frac{R_f}{R_g}$$

4.2 Op-amp characteristics

4.2.1 Ideal op-amps

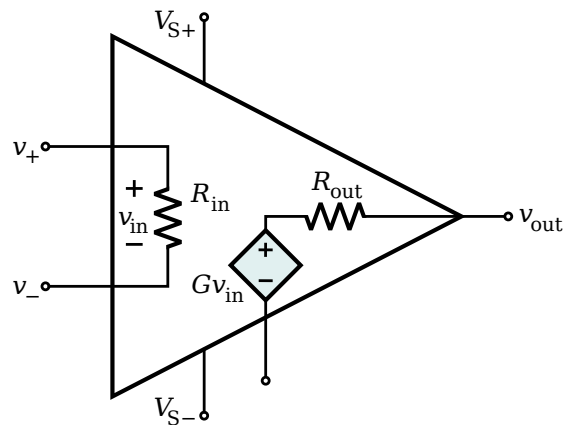

An equivalent circuit of an operational amplifier that models some resistive non-ideal parameters.

An ideal op-amp is usually considered to have the following properties:

- Infinite open-loop gain $G = v_{out} / v_{in}$
- Infinite input impedance R_{in} , and so zero input current
- Zero input offset voltage
- Infinite voltage range available at the output
- Infinite bandwidth with zero phase shift and infinite slew rate
- Zero output impedance R_{out}
- Zero noise
- Infinite Common-mode rejection ratio (CMRR)
- Infinite Power supply rejection ratio.

These ideals can be summarized by the two “golden rules”:

- I. The output attempts to do whatever is necessary to make the voltage difference between the inputs zero.
- II. The inputs draw no current.^{[5]:177}

The first rule only applies in the usual case where the op-amp is used in a closed-loop design (negative feedback, where there is a signal path of some sort feeding back from the output to the inverting input). These rules are commonly used as a good first approximation for analyzing or designing op-amp circuits.^{[5]:177}

None of these ideals can be perfectly realized. A real op-amp may be modeled with non-infinite or non-zero parameters using equivalent resistors and capacitors in the op-amp model. The designer can then include these effects into the overall performance of the final circuit. Some parameters may turn out to have negligible effect on the final design while others represent actual limitations of the final performance that must be evaluated.

4.2.2 Real op-amps

Real op-amps differ from the ideal model in various aspects.

DC imperfections

Real operational amplifiers suffer from several non-ideal effects:

Finite gain Open-loop gain is infinite in the ideal operational amplifier but finite in real operational amplifiers. Typical devices exhibit open-loop DC gain ranging from 100,000 to over 1 million. So long as the loop gain (i.e., the product of open-loop and

feedback gains) is very large, the circuit gain will be determined entirely by the amount of negative feedback (i.e., it will be independent of open-loop gain). In cases where closed-loop gain must be very high, the feedback gain will be very low, and the low feedback gain causes low loop gain; in these cases, the operational amplifier will cease to behave ideally.

Finite input impedances The *differential input impedance* of the operational amplifier is defined as the impedance *between* its two inputs; the *common-mode input impedance* is the impedance from each input to ground. MOSFET-input operational amplifiers often have protection circuits that effectively short circuit any input differences greater than a small threshold, so the input impedance can appear to be very low in some tests. However, as long as these operational amplifiers are used in a typical high-gain negative feedback application, these protection circuits will be inactive. The input bias and leakage currents described below are a more important design parameter for typical operational amplifier applications.

Non-zero output impedance Low output impedance is important for low-impedance loads; for these loads, the voltage drop across the output impedance effectively reduces the open loop gain. In configurations with a voltage-sensing negative feedback, the output impedance of the amplifier is effectively lowered; thus, in linear applications, op-amp circuits usually exhibit a very low output impedance indeed.

Low-impedance outputs typically require high *quiescent* (i.e., *idle*) current in the output stage and will dissipate more power, so low-power designs may purposely sacrifice low output impedance.

Input current Due to biasing requirements or leakage, a small amount of current (typically ~10 nanoamperes for bipolar op-amps, tens of picoamperes (pA) for JFET input stages, and only a few pA for MOSFET input stages) flows into the inputs. When large resistors or sources with high output impedances are used in the circuit, these small currents can produce large unmodeled voltage drops. If the input currents are matched, *and* the impedance looking *out* of *both* inputs are matched, then the voltages produced at each input will be equal. Because the operational amplifier operates on the *difference* between its inputs, these matched voltages will have no effect. It is more common for the input currents to be slightly mismatched. The difference is called input offset current, and even with matched resistances a small *offset voltage* (different from the input offset voltage below) can be produced. This offset voltage can create offsets or drifting in the operational amplifier.

Input offset voltage This voltage, which is what is required across the op-amp's input terminals to drive the output voltage to zero,^{[6][nb 1]} is related to the mismatches in input bias current. In the perfect amplifier, there would be no input offset voltage. However, it exists in actual op-amps because of imperfections in the differential amplifier that constitutes the input stage of the vast majority of these devices. Input offset voltage creates two problems: First, due to the amplifier's high voltage gain, it virtually assures that the amplifier output will go into saturation if it is operated without negative feedback, even when the input terminals are wired together. Second, in a closed loop, negative feedback configuration, the input offset voltage is amplified along with the signal and this may pose a problem if high precision DC amplification is required or if the input signal is very small.^[nb 2]

Common-mode gain A perfect operational amplifier amplifies only the voltage difference between its two inputs, completely rejecting all voltages that are common to both. However, the differential input stage of an operational amplifier is never perfect, leading to the amplification of these common voltages to some degree. The standard measure of this defect is called the **common-mode rejection ratio** (denoted CMRR). Minimization of common mode gain is usually important in non-inverting amplifiers (described below) that operate at high amplification.

Power-supply rejection The output of a perfect operational amplifier will be completely independent from ripples that arrive on its power supply inputs. Every real operational amplifier has a specified **power supply rejection ratio** (PSRR) that reflects how well the op-amp can reject changes in its supply voltage. Copious use of **bypass capacitors** can improve the PSRR of many devices, including the operational amplifier.

Temperature effects All parameters change with temperature. Temperature drift of the input offset voltage is especially important.

Drift Real op-amp parameters are subject to slow change over time and with changes in temperature, input conditions, etc.

Noise Amplifiers generate random voltage at the output even when there is no signal applied. This can be due to thermal noise and flicker noise of the devices. For applications with high gain or high bandwidth, noise becomes a very important consideration.

AC imperfections

The op-amp gain calculated at DC does not apply at higher frequencies. Thus, for high-speed operation, more sophisticated considerations must be used in an op-amp circuit design.

Finite bandwidth All amplifiers have finite bandwidth.

To a first approximation, the op-amp has the frequency response of an **integrator** with gain. That is, the gain of a typical op-amp is inversely proportional to frequency and is characterized by its **gain-bandwidth product** (GBWP). For example, an op-amp with a GBWP of 1 MHz would have a gain of 5 at 200 kHz, and a gain of 1 at 1 MHz. This dynamic response coupled with the very high DC gain of the op-amp gives it the characteristics of a first-order **low-pass filter** with very high DC gain and low cutoff frequency given by the GBWP divided by the DC gain.

The finite bandwidth of an op-amp can be the source of several problems, including:

- **Stability.** Associated with the bandwidth limitation is a phase difference between the input signal and the amplifier output that can lead to **oscillation** in some feedback circuits. For example, a sinusoidal output signal meant to interfere destructively with an input signal of the same frequency will interfere constructively if delayed by 180 degrees forming **positive feedback**. In these cases, the feedback circuit can be **stabilized** by means of **frequency compensation**, which increases the **gain or phase margin** of the open-loop circuit. The circuit designer can implement this compensation externally with a separate circuit component. Alternatively, the compensation can be implemented within the operational amplifier with the addition of a **dominant pole** that sufficiently attenuates the high-frequency gain of the operational amplifier. The location of this pole may be fixed internally by the manufacturer or configured by the circuit designer using methods specific to the op-amp. In general, dominant-pole frequency compensation reduces the bandwidth of the op-amp even further. When the desired closed-loop gain is high, op-amp frequency compensation is often not needed because the requisite open-loop gain is sufficiently low; consequently, applications with high closed-loop gain can make use of op-amps with higher bandwidths.

- **Noise, Distortion, and Other Effects.**

Reduced bandwidth also results in lower amounts of feedback at higher frequencies, producing higher distortion, noise, and output impedance and also reduced output phase linearity as the frequency increases.

Typical low-cost, general-purpose op-amps exhibit a GBWP of a few megahertz. Specialty and high-speed op-amps exist that can achieve a GBWP of hundreds of megahertz. For very high-frequency circuits, a **current-feedback operational amplifier** is often used.

Input capacitance Most important for high frequency operation because it further reduces the open-loop bandwidth of the amplifier.

Common-mode gain See DC imperfections, above.

Non-linear imperfections

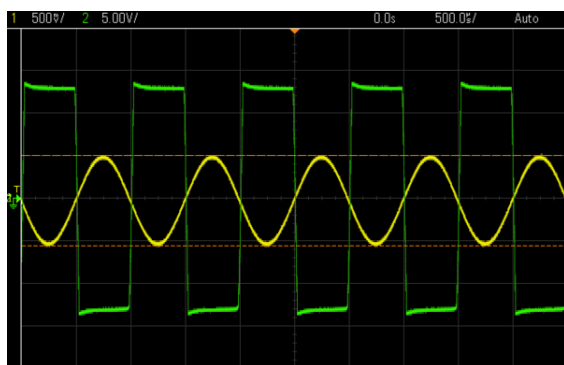

The input (yellow) and output (green) of a saturated op amp in an inverting amplifier

Saturation Output voltage is limited to a minimum and maximum value close to the power supply voltages.^[nb 3] The output of older op-amps can reach to within one or two volts of the supply rails. The output of newer so-called “rail to rail” op-amps can reach to within millivolts of the supply rails when providing low output currents.

Slewing The amplifier’s output voltage reaches its maximum rate of change, the **slew rate**, usually specified in volts per microsecond. When slewing occurs, further increases in the input signal have no effect on the rate of change of the output. Slewing is usually caused by the input stage saturating; the result is a constant current i driving a capacitance C in the amplifier (especially those capacitances used to implement its frequency compensation); the slew rate is limited by $dv/dt=i/C$.

Slewing is associated with the *large-signal* performance of an op-amp. Consider for, example an op-amp configured for a gain of 10. Let the input be a 1 V, 100 kHz sawtooth wave. That is, the amplitude is 1 V and the period is 10 microseconds. Accordingly, the rate of change (i.e., the slope) of the input is 0.1 V per microsecond. After 10x amplification, the output should be a 10 V, 100 kHz sawtooth, with a corresponding slew rate of 1 V per microsecond. However, the classic 741 op-amp has a 0.5 V per microsecond slew rate specification, so that its output can rise to no more than 5 V in the sawtooth’s 10 microsecond period. Thus, if one were to measure the output, it would be a 5 V, 100 kHz sawtooth, rather than a 10 V, 100 kHz sawtooth.

Next consider the same amplifier and 100 kHz sawtooth, but now the input amplitude is 100 mV rather than 1 V. After 10x amplification the output is a 1 V, 100 kHz sawtooth with a corresponding slew rate of 0.1 V per microsecond. In this instance the 741 with its 0.5 V per microsecond slew rate will amplify the input properly.

Modern high speed op-amps can have slew rates in excess of 5,000 V per microsecond. However, it is more common for op-amps to have slew rates in the range 5-100 V per microsecond. For example, the general purpose TL081 op-amp has a slew rate of 13 V per microsecond. As a general rule, low power and small bandwidth op-amps have low slew rates. As an example, the LT1494 micropower op-amp consumes 1.5 microamp but has a 2.7 kHz gain-bandwidth product and a 0.001 V per microsecond slew rate.

Non-linear input-output relationship The output voltage may not be accurately proportional to the difference between the input voltages. It is commonly called distortion when the input signal is a waveform. This effect will be very small in a practical circuit where substantial negative feedback is used.

Phase reversal In some integrated op-amps, when the published common mode voltage is violated (e.g. by one of the inputs being driven to one of the supply voltages), the output may slew to the opposite polarity from what is expected in normal operation.^{[7][8]} Under such conditions, negative feedback becomes positive, likely causing the circuit to “lock up” in that state.

Power considerations

Limited output current The output current must be finite. In practice, most op-amps are designed to limit the output current so as not to exceed a specified level – around 25 mA for a type 741 IC op-amp – thus protecting the op-amp and associated circuitry from damage. Modern designs are electronically more rugged than earlier implementations and some can sustain direct short circuits on their outputs without damage.

Output sink current The output sink current is the maximum current allowed to sink into the output stage. Some manufacturers show the output voltage vs. the output sink current plot, which gives an idea of the output voltage when it is sinking current from another source into the output pin.

Limited dissipated power The output current flows through the op-amp’s internal output impedance, dissipating heat. If the op-amp dissipates too much power, then its temperature will increase above some safe limit. The op-amp may enter thermal shutdown, or it may be destroyed.

Modern integrated FET or MOSFET op-amps approximate more closely the ideal op-amp than bipolar ICs when it comes to input impedance and input bias currents. Bipolars are generally better when it comes to input voltage offset, and often have lower noise. Generally, at room temperature, with a fairly large signal, and limited bandwidth, FET and MOSFET op-amps now offer better performance.

4.3 Internal circuitry of 741-type op-amp

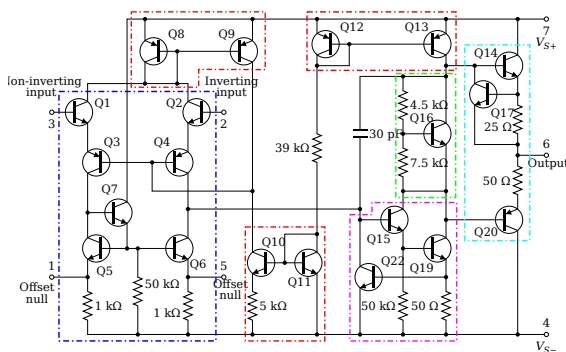

A component-level diagram of the common 741 op-amp. Dotted lines outline: current mirrors (red); differential amplifier (blue); class A gain stage (magenta); voltage level shifter (green); output stage (cyan).

Sourced by many manufacturers, and in multiple similar products, an example of a bipolar transistor operational

amplifier is the 741 integrated circuit designed by Dave Fullagar at Fairchild Semiconductor after Bob Widlar’s LM301 integrated circuit design.^[9] In this discussion, we use the parameters of the Hybrid- π model to characterize the small-signal, grounded emitter characteristics of a transistor. In this model, the current gain of a transistor is denoted h_{fe} , more commonly called the β .^[10]

4.3.1 Architecture

A small-scale integrated circuit, the 741 op-amp shares with most op-amps an internal structure consisting of three gain stages:

1. **Differential amplifier** (outlined blue) — provides high differential amplification (gain), with rejection of common-mode signal, low noise, high input impedance, and drives a
2. **Voltage amplifier** (outlined magenta) — provides high voltage gain, a single-pole frequency roll-off, and in turn drives the
3. **Output amplifier** (outlined cyan and green) — provides high current gain (low output impedance), along with output current limiting, and output short-circuit protection.

Additionally, it contains current mirror (outlined red) bias circuitry and a gain-stabilization capacitor (30 pF).

Differential amplifier

A cascaded differential amplifier followed by a current-mirror active load, the input stage (outlined in blue) is a transconductance amplifier, turning a differential voltage signal at the bases of Q1, Q2 into a current signal into the base of Q15.

It entails two cascaded transistor pairs, satisfying conflicting requirements. The first stage consists of the matched NPN emitter follower pair Q1, Q2 that provide high input impedance. The second is the matched PNP common-base pair Q3, Q4 that eliminates the undesirable Miller effect; it drives an active load Q7 plus matched pair Q5, Q6.

That active load is implemented as a modified Wilson current mirror; its role is to convert the (differential) input current signal to a single-ended signal without the attendant 50% losses (increasing the op-amp’s open-loop gain by 3 dB).^[nb 4] Thus, a small-signal differential current in Q3 versus Q4 appears summed (doubled) at the base of Q15, the input of the voltage gain stage.

Voltage amplifier

The (class-A) voltage gain stage (outlined in magenta) consists of the two NPN transistors Q15/Q19 connected

in a **Darlington configuration** and uses the output side of current mirror Q12/Q13 as its collector (dynamic) load to achieve its high voltage gain. The output sink transistor Q20 receives its base drive from the common collectors of Q15 and Q19; the level-shifter Q16 provides base drive for the output source transistor Q14. .

The transistor Q22 prevents this stage from delivering excessive current to Q20 and thus limits the output sink current.

Output amplifier

The output stage (Q14, Q20, outlined in cyan) is a **Class AB push-pull emitter follower amplifier**. It provides an output drive with impedance of $\approx 50\Omega$, in essence, current gain. Transistor Q16 (outlined in green) provides the quiescent current for the output transistors, and Q17 provides output current limiting.

4.3.2 Biasing circuits

Provide appropriate quiescent current for each stage of the op-amp.

The resistor (39 k Ω) connecting the (diode-connected) Q11 and Q12, and the given supply voltage ($V_{S+} - V_{S-}$), determine the current in the **current mirrors**, (matched pairs) Q10/Q11 and Q12/Q13. The collector current of Q11, $i_{11} * 39 \text{ k}\Omega = V_{S+} - V_{S-} - 2 V_{BE}$. For the typical $V_S = \pm 20 \text{ V}$, the standing current in Q11/Q12 (as well as in Q13) would be $\approx 1 \text{ mA}$. A supply current for a typical 741 of about 2 mA agrees with the notion that these two bias currents dominate the quiescent supply current.

Transistors Q11 and Q10 form a **Widlar current mirror**, with quiescent current in Q10 i_{10} such that $\ln(i_{11} / i_{10}) = i_{10} * 5 \text{ k}\Omega / 28 \text{ mV}$, where 5 k Ω represents the emitter resistor of Q10, and 28 mV is V_T , the **thermal voltage** at room temperature. In this case $i_{10} \approx 20 \mu\text{A}$.

Differential amplifier

The biasing circuit of this stage is set by a feedback loop that forces the collector currents of Q10 and Q9 to (nearly) match. The small difference in these currents provides the drive for the common base of Q3/Q4 (note that the base drive for input transistors Q1/Q2 is the input bias current and must be sourced externally). The summed quiescent currents of Q1/Q3 plus Q2/Q4 is mirrored from Q8 into Q9, where it is summed with the collector current in Q10, the result being applied to the bases of Q3/Q4.

The quiescent currents of Q1/Q3 (resp., Q2/Q4) i_1 will thus be half of i_{10} , of order $\approx 10 \mu\text{A}$. Input bias current for the base of Q1 (resp. Q2) will amount to i_1 / β ; typically $\approx 50 \text{ nA}$, implying a current gain $h_{fe} \approx 200$ for Q1(Q2).

This feedback circuit tends to draw the common base node of Q3/Q4 to a voltage $V_{com} - 2 * V_{BE}$, where V_{com} is the input common-mode voltage. At the same time, the magnitude of the quiescent current is relatively insensitive to the characteristics of the components Q1–Q4, such as h_{fe} , that would otherwise cause temperature dependence or part-to-part variations.

Transistor Q7 drives Q5 and Q6 into conduction until their (equal) collector currents match that of Q1/Q3 and Q2/Q4. The quiescent current in Q7 is $V_{BE} / 50 \text{ k}\Omega$, about $35 \mu\text{A}$, as is the quiescent current in Q15, with its matching operating point. Thus, the quiescent currents are pairwise matched in Q1/Q2, Q3/Q4, Q5/Q6, and Q7/Q15.

Voltage amplifier

Quiescent currents in Q16 and Q19 are set by the current mirror Q12/Q13, which is running at $\approx 1 \text{ mA}$. Through some (?) mechanism, the collector current in Q19 tracks that standing current.

Output amplifier

In the circuit involving Q16 (variously named **rubber diode** or **VBE multiplier**), the 4.5 k Ω resistor must be conducting about $100 \mu\text{A}$, with the Q16 V_{BE} roughly 700 mV. Then the V_{CB} must be about 0.45 V and V_{CE} at about 1.0 V. Because the Q16 collector is driven by a current source and the Q16 emitter drives into the Q19 collector current sink, the Q16 transistor establishes a voltage difference between Q14 base and Q20 base of $\approx 1 \text{ V}$, regardless of the common-mode voltage of Q14/Q20 base. The standing current in Q14/Q20 will be a factor $\exp(100 \text{ mV} / V_T) \approx 36$ smaller than the 1 mA quiescent current in the class A portion of the op amp. This (small) standing current in the output transistors establishes the output stage in class AB operation and reduces the **crossover distortion** of this stage.

4.3.3 Small-signal differential mode

A small differential input voltage signal gives rise, through multiple stages of current amplification, to a much larger voltage signal on output.

Input impedance

The input stage with Q1 and Q3 is similar to an emitter-coupled pair (long-tailed pair), with Q2 and Q4 adding some degenerating impedance. The input impedance is relatively high because of the small current through Q1–Q4. A typical 741 op amp has an differential input impedance of about 2 M Ω . The common mode input

impedance is even higher, as the input stage works at an essentially constant current.

Differential amplifier

A differential voltage V_{I_n} at the op-amp inputs (pins 3 and 2, respectively) gives rise to a small differential current in the bases of Q1 and Q2 $i_{I_n} \approx V_{I_n} / (2 h_{ie} * h_{fe})$. This differential base current causes a change in the differential collector current in each leg by $i_{I_n} * h_{fe}$. Introducing the transconductance of Q1, $g_m = h_{fe} / h_{ie}$, the (small-signal) current at the base of Q15 (the input of the voltage gain stage) is $V_{I_n} * g_m / 2$.

This portion of the op amp cleverly changes a differential signal at the op amp inputs to a single-ended signal at the base of Q15, and in a way that avoids wastefully discarding the signal in either leg. To see how, notice that a small negative change in voltage at the inverting input (Q2 base) drives it out of conduction, and this incremental decrease in current passes directly from Q4 collector to its emitter, resulting in an decrease in base drive for Q15. On the other hand, a small positive change in voltage at the non-inverting input (Q1 base) drives this transistor into conduction, reflected in an increase in current at the collector of Q3. This current drives Q7 further into conduction, which turns on current mirror Q5/Q6. Thus, the increase in Q3 emitter current is mirrored in an increase in Q6 collector current, resulting also in a decrease in base drive for Q15. Besides avoiding wasting 3 dB of gain here, this technique decreases common-mode gain and feedthrough of power supply noise.

Voltage amplifier

A current signal i at Q15's base gives rise to a current in Q19 of order $i * \beta^2$ (the product of the h_{fe} of each of Q15 and Q19, which are connected in a Darlington pair). This current signal develops a voltage at the bases of output transistors Q14/Q20 proportional to the h_{ie} of the respective transistor.

Output amplifier

Output transistors Q14 and Q20 are each configured as an emitter follower, so no voltage gain occurs there; instead, this stage provides current gain, equal to the h_{fe} of Q14 (resp. Q20).

The output impedance is not zero, as it would be in an ideal op-amp, but with negative feedback it approaches zero at low frequencies.

Overall open-loop voltage gain

The net open-loop small-signal voltage gain of the op amp involves the product of the current gain h_{fe} of some 4 tran-

sistors. In practice, the voltage gain for a typical 741-style op amp is of order 200,000, and the current gain, the ratio of input impedance ($\approx 2-6 \text{ M}\Omega$) to output impedance ($\approx 50\Omega$) provides yet more (power) gain.

4.3.4 Other linear characteristics

Small-signal common mode gain

The ideal op amp has infinite common-mode rejection ratio, or zero common-mode gain.

In the present circuit, if the input voltages change in the same direction, the negative feedback makes Q3/Q4 base voltage follow (with $2V_{BE}$ below) the input voltage variations. Now the output part (Q10) of Q10-Q11 current mirror keeps up the common current through Q9/Q8 constant in spite of varying voltage. Q3/Q4 collector currents, and accordingly the output current at the base of Q15, remain unchanged.

In the typical 741 op amp, the common-mode rejection ratio is 90 dB, implying an open-loop common-mode voltage gain of about 6.

Frequency compensation

The innovation of the Fairchild $\mu\text{A}741$ was the introduction of frequency compensation via an on-chip (monolithic) capacitor, simplifying application of the op amp by eliminating the need for external components for this function. The 30 pF capacitor stabilizes the amplifier via Miller compensation and functions in a manner similar to an op-amp integrator circuit. Also known as 'dominant pole compensation' because it introduces a pole that masks (dominates) the effects of other poles into the open loop frequency response; in a 741 op amp this pole can be as low as 10 Hz (where it causes a -3 dB loss of open loop voltage gain).

This internal compensation is provided to achieve unconditional stability of the amplifier in negative feedback configurations where the feedback network is non-reactive and the closed loop gain is unity or higher. By contrast, amplifiers requiring external compensation, such as the $\mu\text{A}748$, may require external compensation or closed-loop gains significantly higher than unity.

Input offset voltage

The "offset null" pins may be used to place external resistors (typically in the form of the two ends of a potentiometer, with the slider connected to $VS-$) in parallel with the emitter resistors of Q5 and Q6, to adjust the balance of the Q5/Q6 current mirror. The potentiometer is adjusted such that the output is null (midrange) when the inputs are shorted together.

4.3.5 Non-linear characteristics

Input breakdown voltage

The transistors Q3, Q4 help to increase the reverse V_{BE} rating: the base-emitter junctions of the NPN transistors Q1 and Q2 break down at around 7V, but the PNP transistors Q3 and Q4 have V_{BE} breakdown voltages around 50 V.^[11]

Output-stage voltage swing and current limiting

Variations in the quiescent current with temperature, or between parts with the same type number, are common, so crossover distortion and quiescent current may be subject to significant variation.

The output range of the amplifier is about one volt less than the supply voltage, owing in part to V_{BE} of the output transistors Q14 and Q20.

The 25 Ω resistor at the Q14 emitter, along with Q17, acts to limit Q14 current to about 25 mA; otherwise, Q17 conducts no current.

Current limiting for Q20 is performed in the voltage gain stage: Q22 senses the voltage across Q19's emitter resistor (50 Ω); as it turns on, it diminishes the drive current to Q15 base.

Later versions of this amplifier schematic may show a somewhat different method of output current limiting.

4.3.6 Applicability considerations

Note: while the 741 was historically used in audio and other sensitive equipment, such use is now rare because of the improved noise performance of more modern op-amps. Apart from generating noticeable hiss, 741s and other older op-amps may have poor common-mode rejection ratios and so will often introduce cable-borne mains hum and other common-mode interference, such as switch 'clicks', into sensitive equipment.

The "741" has come to often mean a generic op-amp IC (such as μ A741, LM301, 558, LM324, TBA221 — or a more modern replacement such as the TL071). The description of the 741 output stage is qualitatively similar for many other designs (that may have quite different input stages), except:

- Some devices (μ A748, LM301, LM308) are not internally compensated (require an external capacitor from output to some point within the operational amplifier, if used in low closed-loop gain applications).
- Some modern devices have "rail-to-rail output" capability, meaning that the output can range from

within a few millivolts of the positive supply voltage to within a few millivolts of the negative supply voltage.

4.4 Classification

Op-amps may be classified by their construction:

- discrete (built from individual transistors or tubes/valves)
- IC (fabricated in an Integrated circuit) — most common
- hybrid

IC op-amps may be classified in many ways, including:

- Military, Industrial, or Commercial grade (for example: the LM301 is the commercial grade version of the LM101, the LM201 is the industrial version). This may define operating temperature ranges and other environmental or quality factors.
- Classification by package type may also affect environmental hardness, as well as manufacturing options; DIP, and other through-hole packages are tending to be replaced by surface-mount devices.
- Classification by internal compensation: op-amps may suffer from high frequency instability in some negative feedback circuits unless a small compensation capacitor modifies the phase and frequency responses. Op-amps with a built-in capacitor are termed "compensated", or perhaps compensated for closed-loop gains down to (say) 5. All others are considered uncompensated.
- Single, dual and quad versions of many commercial op-amp IC are available, meaning 1, 2 or 4 operational amplifiers are included in the same package.
- Rail-to-rail input (and/or output) op-amps can work with input (and/or output) signals very close to the power supply rails.
- CMOS op-amps (such as the CA3140E) provide extremely high input resistances, higher than JFET-input op-amps, which are normally higher than bipolar-input op-amps.
- other varieties of op-amp include programmable op-amps (simply meaning the quiescent current, gain, bandwidth and so on can be adjusted slightly by an external resistor).
- manufacturers often tabulate their op-amps according to purpose, such as low-noise pre-amplifiers, wide bandwidth amplifiers, and so on.

4.5 Applications

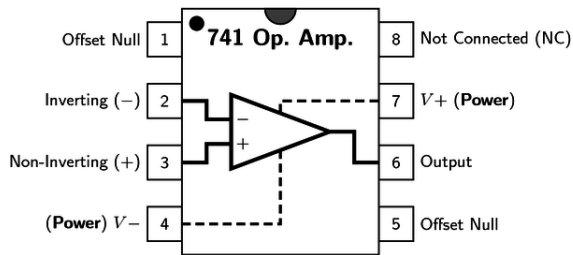

DIP pinout for 741-type operational amplifier

Main article: Operational amplifier applications

4.5.1 Use in electronics system design

The use of op-amps as circuit blocks is much easier and clearer than specifying all their individual circuit elements (transistors, resistors, etc.), whether the amplifiers used are integrated or discrete circuits. In the first approximation op-amps can be used as if they were ideal differential gain blocks; at a later stage limits can be placed on the acceptable range of parameters for each op-amp.

Circuit design follows the same lines for all electronic circuits. A specification is drawn up governing what the circuit is required to do, with allowable limits. For example, the gain may be required to be 100 times, with a tolerance of 5% but drift of less than 1% in a specified temperature range; the input impedance not less than one megohm; etc.

A basic circuit is designed, often with the help of circuit modeling (on a computer). Specific commercially available op-amps and other components are then chosen that meet the design criteria within the specified tolerances at acceptable cost. If not all criteria can be met, the specification may need to be modified.

A prototype is then built and tested; changes to meet or improve the specification, alter functionality, or reduce the cost, may be made.

4.5.2 Applications without using any feedback

That is, the op-amp is being used as a **voltage comparator**. Note that a device designed primarily as a comparator may be better if, for instance, speed is important or a wide range of input voltages may be found, since such devices can quickly recover from full on or full off (“saturated”) states.

A **voltage level detector** can be obtained if a reference voltage V_{ref} is applied to one of the op-amp’s inputs. This

means that the op-amp is set up as a comparator to detect a positive voltage. If the voltage to be sensed, E_i , is applied to op amp’s (+) input, the result is a noninverting positive-level detector: when E_i is above V_{ref} , VO equals $+V_{sat}$; when E_i is below V_{ref} , VO equals $-V_{sat}$. If E_i is applied to the inverting input, the circuit is an inverting positive-level detector: When E_i is above V_{ref} , VO equals $-V_{sat}$.

A **zero voltage level detector** ($E_i = 0$) can convert, for example, the output of a sine-wave from a function generator into a variable-frequency square wave. If E_i is a sine wave, triangular wave, or wave of any other shape that is symmetrical around zero, the zero-crossing detector’s output will be square. Zero-crossing detection may also be useful in triggering TRIACs at the best time to reduce mains interference and current spikes.

4.5.3 Positive feedback applications

Another typical configuration of op-amps is with positive feedback, which takes a fraction of the output signal back to the non-inverting input. An important application of it is the comparator with hysteresis, the **Schmitt trigger**. Some circuits may use *Positive* feedback and *Negative* feedback around the same amplifier, for example **Triangle wave oscillators** and **active filters**.

Because of the wide slew-range and lack of positive feedback, the response of all the open-loop level detectors described above will be relatively slow. External overall positive feedback may be applied but (unlike internal positive feedback that may be applied within the latter stages of a purpose-designed comparator) this markedly affects the accuracy of the zero-crossing detection point. Using a general-purpose op-amp, for example, the frequency of E_i for the sine to square wave converter should probably be below 100 Hz.

4.5.4 Negative feedback applications

Non-inverting amplifier

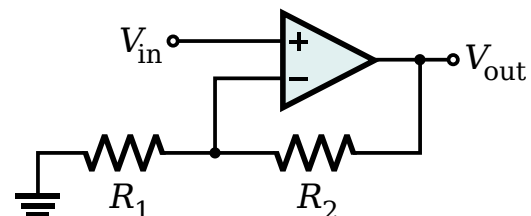

An op-amp connected in the non-inverting amplifier configuration

In a non-inverting amplifier, the output voltage changes in the same direction as the input voltage.

The gain equation for the op-amp is:

$$V_{\text{out}} = A_{OL} (V_+ - V_-)$$

However, in this circuit V_- is a function of V_{out} because of the negative feedback through the R_1 R_2 network. R_1 and R_2 form a voltage divider, and as V_- is a high-impedance input, it does not load it appreciably. Consequently:

$$V_- = \beta \cdot V_{\text{out}}$$

where

$$\beta = \frac{R_1}{R_1 + R_2}$$

Substituting this into the gain equation, we obtain:

$$V_{\text{out}} = A_{OL}(V_{\text{in}} - \beta \cdot V_{\text{out}})$$

Solving for V_{out} :

$$V_{\text{out}} = V_{\text{in}} \left(\frac{1}{\beta + 1/A_{OL}} \right)$$

If A_{OL} is very large, this simplifies to

$$V_{\text{out}} \approx \frac{V_{\text{in}}}{\beta} = \frac{V_{\text{in}}}{\frac{R_1}{R_1 + R_2}} = V_{\text{in}} \left(1 + \frac{R_2}{R_1} \right)$$

The non-inverting input of the operational amplifier needs a path for DC to ground; if the signal source does not supply a DC path, or if that source requires a given load impedance, then the circuit will require another resistor from the non-inverting input to ground. When the operational amplifier's input bias currents are significant, then the DC source resistances driving the inputs should be balanced.^[12] The ideal value for the feedback resistors (to give minimum offset voltage) will be such that the two resistances in parallel roughly equal the resistance to ground at the non-inverting input pin. That ideal value assumes the bias currents are well-matched, which may not be true for all op-amps.^[13]

Inverting amplifier

In an inverting amplifier, the output voltage changes in an opposite direction to the input voltage.

As with the non-inverting amplifier, we start with the gain equation of the op-amp:

$$V_{\text{out}} = A_{OL} (V_+ - V_-)$$

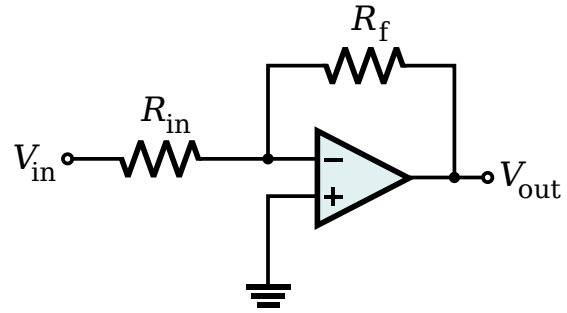

An op-amp connected in the inverting amplifier configuration

This time, V_- is a function of both V_{out} and V_{in} due to the voltage divider formed by R_f and R_{in} . Again, the op-amp input does not apply an appreciable load, so:

$$V_- = \frac{1}{R_f + R_{\text{in}}} (R_f V_{\text{in}} + R_{\text{in}} V_{\text{out}})$$

Substituting this into the gain equation and solving for V_{out} :

$$V_{\text{out}} = -V_{\text{in}} \cdot \frac{A_{OL} R_f}{R_f + R_{\text{in}} + A_{OL} R_{\text{in}}}$$

If A_{OL} is very large, this simplifies to

$$V_{\text{out}} \approx -V_{\text{in}} \frac{R_f}{R_{\text{in}}}$$

A resistor is often inserted between the non-inverting input and ground (so both inputs “see” similar resistances), reducing the input offset voltage due to different voltage drops due to bias current, and may reduce distortion in some op-amps.

A **DC-blocking capacitor** may be inserted in series with the input resistor when a **frequency response** down to DC is not needed and any DC voltage on the input is unwanted. That is, the capacitive component of the input impedance inserts a **DC zero** and a low-frequency **pole** that gives the circuit a **bandpass** or **high-pass** characteristic.

The potentials at the operational amplifier inputs remain virtually constant (near ground) in the inverting configuration. The constant operating potential typically results in distortion levels that are lower than those attainable with the non-inverting topology.

4.5.5 Other applications

- audio- and video-frequency pre-amplifiers and buffers
- differential amplifiers

- differentiators and integrators
- filters
- precision rectifiers
- precision peak detectors
- voltage and current regulators
- analog calculators
- analog-to-digital converters
- digital-to-analog converters
- Voltage clamping
- oscillators and waveform generators

Most single, dual and quad op-amps available have a standardized pin-out which permits one type to be substituted for another without wiring changes. A specific op-amp may be chosen for its open loop gain, bandwidth, noise performance, input impedance, power consumption, or a compromise between any of these factors.

4.6 Historical timeline

1941: A vacuum tube op-amp. An op-amp, defined as a general-purpose, DC-coupled, high gain, inverting feedback amplifier, is first found in U.S. Patent 2,401,779 “Summing Amplifier” filed by Karl D. Swartzel Jr. of Bell Labs in 1941. This design used three vacuum tubes to achieve a gain of 90 dB and operated on voltage rails of ± 350 V. It had a single inverting input rather than differential inverting and non-inverting inputs, as are common in today’s op-amps. Throughout World War II, Swartzel’s design proved its value by being liberally used in the M9 artillery director designed at Bell Labs. This artillery director worked with the SCR584 radar system to achieve extraordinary hit rates (near 90%) that would not have been possible otherwise.^[14]

1947: An op-amp with an explicit non-inverting input. In 1947, the operational amplifier was first formally defined and named in a paper^[15] by John R. Ragazzini of Columbia University. In this same paper a footnote mentioned an op-amp design by a student that would turn out to be quite significant. This op-amp, designed by Loebe Julie, was superior in a variety of ways. It had two major innovations. Its input stage used a long-tailed triode pair with loads matched to reduce drift in the output and, far more importantly, it was the first op-amp design to have two inputs (one inverting, the other non-inverting). The differential input made a whole range of new functionality possible, but it would not be used for a long time due to the rise of the chopper-stabilized amplifier.^[14]

1949: A chopper-stabilized op-amp. In 1949, Edwin A. Goldberg designed a chopper-stabilized op-amp.^[16]



GAP/R's K2-W: a vacuum-tube op-amp (1953)

This set-up uses a normal op-amp with an additional AC amplifier that goes alongside the op-amp. The chopper gets an AC signal from DC by switching between the DC voltage and ground at a fast rate (60 Hz or 400 Hz). This signal is then amplified, rectified, filtered and fed into the op-amp’s non-inverting input. This vastly improved the gain of the op-amp while significantly reducing the output drift and DC offset. Unfortunately, any design that used a chopper couldn’t use their non-inverting input for any other purpose. Nevertheless, the much improved characteristics of the chopper-stabilized op-amp made it the dominant way to use op-amps. Techniques that used the non-inverting input regularly would not be very popular until the 1960s when op-amp ICs started to show up in the field.

1953: A commercially available op-amp. In 1953, vacuum tube op-amps became commercially available with the release of the model K2-W from George A. Philbrick Researches, Incorporated. The designation on the de-

vices shown, GAP/R, is an acronym for the complete company name. Two nine-pin 12AX7 vacuum tubes were mounted in an octal package and had a model K2-P chopper add-on available that would effectively “use up” the non-inverting input. This op-amp was based on a descendant of Loebe Julie’s 1947 design and, along with its successors, would start the widespread use of op-amps in industry.



GAP/R’s model P45: a solid-state, discrete op-amp (1961).

1961: A discrete IC op-amp. With the birth of the transistor in 1947, and the silicon transistor in 1954, the concept of ICs became a reality. The introduction of the planar process in 1959 made transistors and ICs stable enough to be commercially useful. By 1961, solid-state, discrete op-amps were being produced. These op-amps were effectively small circuit boards with packages such as edge connectors. They usually had hand-selected resistors in order to improve things such as voltage offset and drift. The P45 (1961) had a gain of 94 dB and ran on ± 15 V rails. It was intended to deal with signals in the range of ± 10 V.

1961: A varactor bridge op-amp. There have been many different directions taken in op-amp design. Varactor bridge op-amps started to be produced in the early 1960s.^{[17][18]} They were designed to have extremely small input current and are still amongst the best op-amps available in terms of common-mode rejection with the ability to correctly deal with hundreds of volts at their inputs.

1962: An op-amp in a potted module. By 1962, several companies were producing modular potted packages that could be plugged into printed circuit boards. These packages were crucially important as they made the operational amplifier into a single black box which could be easily treated as a component in a larger circuit.

1963: A monolithic IC op-amp. In 1963, the first monolithic IC op-amp, the μ A702 designed by Bob Widlar at Fairchild Semiconductor, was released. Monolithic ICs consist of a single chip as opposed to a chip and discrete parts (a discrete IC) or multiple chips bonded and connected on a circuit board (a hybrid IC). Almost all

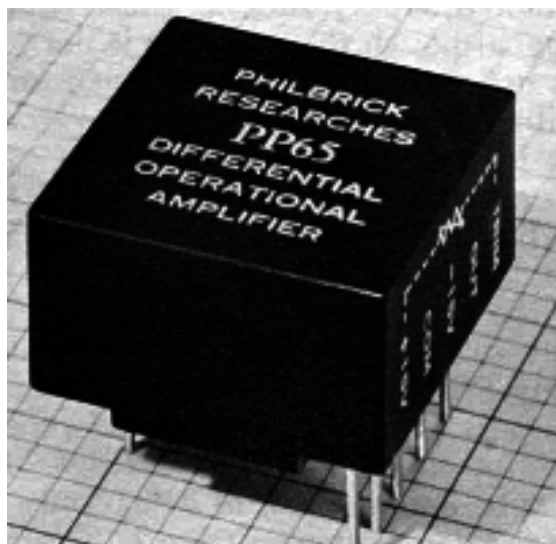

GAP/R’s model PP65: a solid-state op-amp in a potted module (1962)

modern op-amps are monolithic ICs; however, this first IC did not meet with much success. Issues such as an uneven supply voltage, low gain and a small dynamic range held off the dominance of monolithic op-amps until 1965 when the μ A709^[19] (also designed by Bob Widlar) was released.

1968: Release of the μ A741. The popularity of monolithic op-amps was further improved upon the release of the LM101 in 1967, which solved a variety of issues, and the subsequent release of the μ A741 in 1968. The μ A741 was extremely similar to the LM101 except that Fairchild’s facilities allowed them to include a 30 pF compensation capacitor inside the chip instead of requiring external compensation. This simple difference has made the 741 the canonical op-amp and many modern amps base their pinout on the 741s. The μ A741 is still in production, and has become ubiquitous in electronics—many manufacturers produce a version of this classic chip, recognizable by part numbers containing 741. The same part is manufactured by several companies.

1970: First high-speed, low-input current FET design. In the 1970s high speed, low-input current designs started to be made by using FETs. These would be largely replaced by op-amps made with MOSFETs in the 1980s. During the 1970s single sided supply op-amps also became available.

1972: Single sided supply op-amps being produced. A single sided supply op-amp is one where the input and output voltages can be as low as the negative power supply voltage instead of needing to be at least two volts above it. The result is that it can operate in many applications with the negative supply pin on the op-amp being connected to the signal ground, thus eliminating the need for a separate negative power supply.

The LM324 (released in 1972) was one such op-amp that

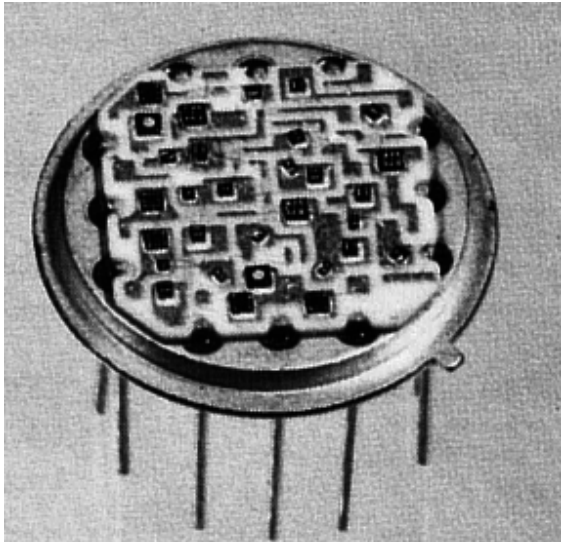

ADI's HOS-050: a high speed hybrid IC op-amp (1979)

came in a quad package (four separate op-amps in one package) and became an industry standard. In addition to packaging multiple op-amps in a single package, the 1970s also saw the birth of op-amps in hybrid packages. These op-amps were generally improved versions of existing monolithic op-amps. As the properties of monolithic op-amps improved, the more complex hybrid ICs were quickly relegated to systems that are required to have extremely long service lives or other specialty systems.

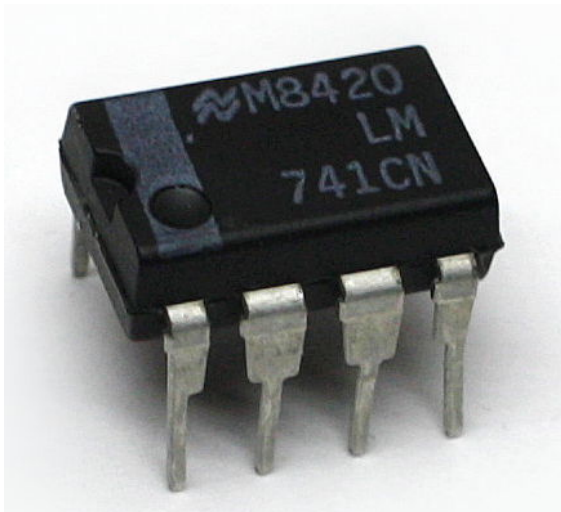

An op-amp in a modern mini DIP

Recent trends. Recently supply voltages in analog circuits have decreased (as they have in digital logic) and low-voltage op-amps have been introduced reflecting this. Supplies of ± 5 V and increasingly 3.3 V (sometimes as low as 1.8 V) are common. To maximize the signal range modern op-amps commonly have rail-to-rail output (the output signal can range from the lowest supply voltage to the highest) and sometimes rail-to-rail inputs.

4.7 See also

- Operational amplifier applications
- Differential amplifier
- Instrumentation amplifier
- Active filter
- Current-feedback operational amplifier
- Operational transconductance amplifier
- George A. Philbrick
- Bob Widlar
- Analog computer
- Negative feedback amplifier
- Current conveyor

4.8 Notes

- [1] This definition hews to the convention of measuring op-amp parameters with respect to the zero voltage point in the circuit, which is usually half the total voltage between the amplifier's positive and negative power rails.
- [2] Many older designs of operational amplifiers have offset null inputs to allow the offset to be manually adjusted away. Modern precision op-amps can have internal circuits that automatically cancel this offset using choppers or other circuits that measure the offset voltage periodically and subtract it from the input voltage.
- [3] That the output cannot reach the power supply voltages is usually the result of limitations of the amplifier's output stage transistors. See [Output stage](#).
- [4] Widlar used this same trick in $\mu A702$ and $\mu A709$

4.9 References

- [1] Maxim Application Note 1108: Understanding Single-Ended, Pseudo-Differential and Fully-Differential ADC Inputs – Retrieved November 10, 2007
- [2] Analog devices MT-044 Tutorial
- [3] “Burson Opamp”. Parts Connexion. Retrieved 24 September 2012. BURSON-71484 Dual Discrete Op Amp Modules, pair pcX Selling Price: \$179.95/pr BURSON-71485 Dual Discrete OpAmp Module, single pcX Selling Price: \$89.95 each. BURSON-71486 Single Discrete Op Amp Modules, pair pcX Selling Price: \$114.95/pr. Quantity discounts for Modifiers and OEM's
- [4] Jacob Millman, *Microelectronics: Digital and Analog Circuits and Systems*, McGraw-Hill, 1979, ISBN 0-07-042327-X, pp. 523-527

- [5] Horowitz, Paul; Hill, Winfield (1989). *The Art of Electronics*. Cambridge, UK: Cambridge University Press. ISBN 0-521-37095-7.
- [6] D.F. Stout *Handbook of Operational Amplifier Circuit Design* (McGraw-Hill, 1976, ISBN 0-07-061797-X) pp. 1–11.
- [7] “Op Amp Output Phase-Reversal and Input Over-Voltage Protection”. Analog Devices. 2009. Retrieved 2012-12-27.
- [8] King, Grayson; Watkins, Tim (13 May 1999). “Bootstrapping your op amp yields wide voltage swings”. *Electronic Design News*. Retrieved 2012-12-27.
- [9] Lee, Thomas H. (November 18, 2002). “IC Op-Amps Through the Ages”. Stanford University Handout #18: EE214 Fall 2002.
- [10] Lu, Liang-Hung. “Electronics 2, Chapter 10”. National Taiwan University, Graduate Institute of Electronics Engineering. Retrieved 2014-02-22.
- [11] The μ A741 Operational Amplifier
- [12] An input bias current of 1 μ A through a DC source resistance of 10 k Ω produces a 10 mV offset voltage. If the other input bias current is the same and sees the same source resistance, then the two input offset voltages will cancel out. Balancing the DC source resistances may not be necessary if the input bias current and source resistance product is small.
- [13] <http://www.analog.com/static/imported-files/tutorials/MT-038.pdf>
- [14] Jung, Walter G. (2004). “Chapter 8: Op Amp History”. *Op Amp Applications Handbook*. Newnes. p. 777. ISBN 978-0-7506-7844-5. Retrieved 2008-11-15.
- [15] Ragazzini, John R.; Randall, Robert H.; Russell, Frederick A. (May 1947). “Analysis of Problems in Dynamics by Electronic Circuits”. *Proceedings of the IRE (IEEE)* **35** (5): 444–452. doi:10.1109/JRPROC.1947.232616. ISSN 0096-8390.
- [16] http://www.analog.com/library/analogDialogue/archives/39-05/Web_ChH_final.pdf
- [17] <http://www.philbrickarchive.org/>
- [18] June 1961 advertisement for Philbrick P2, <http://www.philbrickarchive.org/p2%20and%206033%20ad%20rsi%20vol32%20no6%20june1961.pdf>
- [19] A.P. Malvino, *Electronic Principles* (2nd Ed. 1979. ISBN 0-07-039867-4) p. 476.
- *Op Amps For Everyone*; 4th Ed; Ron Mancini; Newnes; 304 pages; 2013; ISBN 978-0123914958. (Free PDF download of older version)
 - *Small Signal Audio Design*; Douglas Self; Focal Press; 556 pages; 2010; ISBN 978-0-240-52177-0.
 - *Op Amp Applications Handbook*; Walt G. Jung; Newnes; 896 pages; 2004; ISBN 978-0750678445. (Free PDF download)
 - *Op Amps and Linear Integrated Circuits*; James M. Fiore; Cengage Learning; 616 pages; 2000; ISBN 978-0766817937.
 - *Operational Amplifiers and Linear Integrated Circuits*; 6th Ed; Robert F Coughlin; Prentice Hall; 529 pages; 2000; ISBN 978-0130149916.
 - *Op-Amps and Linear Integrated Circuits*; 4th Ed; Ram Gayakwad; Prentice Hall; 543 pages; 1999; ISBN 978-0132808682.
 - *Basic Operational Amplifiers and Linear Integrated Circuits*; 2nd Ed; Thomas L Floyd and David Buchla; Prentice Hall; 593 pages; 1998; ISBN 978-0130829870.
 - *Troubleshooting Analog Circuits*; Bob Pease; Newnes; 217 pages; 1991; ISBN 978-0750694995.
 - *IC Op-Amp Cookbook*; 3rd Ed; Walter G. Jung; Prentice Hall; 433 pages; 1986; ISBN 978-0138896010.
 - *Engineer’s Mini-Notebook – OpAmp IC Circuits*; Forrest Mims III; Radio Shack; 49 pages; 1985; ASIN B000DZG196.
 - *Analog Applications Manual*; Signetics; 418 pages; 1979. Chapter 3 OpAmps is 32 pages.

4.11 External links

4.10 Further reading

- *Design with Operational Amplifiers and Analog Integrated Circuits*; 4th Ed; Sergio Franco; McGraw Hill; 672 pages; 2014; ISBN 978-0078028168.
- Operational Amplifiers - Chapter on All About Circuits
- Simple Op Amp Measurements How to measure offset voltage, offset and bias current, gain, CMRR, and PSRR.
- Operational Amplifiers. Introductory on-line text by E. J. Mastascusa (Bucknell University).
- Introduction to op-amp circuit stages, second order filters, single op-amp bandpass filters, and a simple intercom
- *MOS op amp design: A tutorial overview*
- Operational Amplifier Noise Prediction (All Op Amps) using spot noise

- Operational Amplifier Basics
- History of the Op-amp from vacuum tubes to about 2002. Lots of detail, with schematics. IC part is somewhat ADI-centric.
- Loebe Julie historical OpAmp interview by Bob Pease
- www.PhilbrickArchive.org – A free repository of materials from George A Philbrick / Researches - Operational Amplifier Pioneer
- What's The Difference Between Operational Amplifiers And Instrumentation Amplifiers?, Electronic Design Magazine

IC Datasheets

- LM301, Single BJT OpAmp, Texas Instruments
- LM324, Quad BJT OpAmp, Texas Instruments
- LM741, Single BJT OpAmp, Texas Instruments
- NE5532, Dual BJT OpAmp, Texas Instruments (NE5534 is similar single)
- TL072, Dual JFET OpAmp, Texas Instruments (TL074 is Quad)

Chapter 5

Comparator

For other uses, see [Comparator \(disambiguation\)](#).

In electronics, a **comparator** is a device that compares two voltages or currents and outputs a digital signal indicating which is larger. It has two analog input terminals V_+ and V_- and one binary digital output V_o . The output is ideally

$$V_o = \begin{cases} 1, & \text{if } V_+ > V_- \\ 0, & \text{if } V_+ < V_- \end{cases}$$

A comparator consists of a specialized high-gain differential amplifier. They are commonly used in devices that measure and digitize analog signals, such as analog-to-digital converters (ADCs), as well as relaxation oscillators.

5.1 Differential Voltage

The differential voltages must stay within the limits specified by the manufacturer. Early integrated comparators, like the LM111 family, and certain high-speed comparators like the LM119 family, require differential voltage ranges substantially lower than the power supply voltages (± 15 V vs. 36 V).^[1] *Rail-to-rail* comparators allow any differential voltages within the power supply range. When powered from a bipolar (dual rail) supply,

$$V_{S-} \leq V_+, V_- \leq V_{S+}$$

or, when powered from a unipolar TTL/CMOS power supply:

$$0 \leq V_+, V_- \leq V_{cc}$$

Specific rail-to-rail comparators with p-n-p input transistors, like the LM139 family, allow input potential to drop 0.3 volts *below* the negative supply rail, but do not allow it to rise above the positive rail.^[2] Specific ultra-fast comparators, like the LMH7322, allow input signal to swing

below the negative rail *and* above the positive rail, although by a narrow margin of only 0.2 V.^[3] Differential input voltage (the voltage between two inputs) of a modern rail-to-rail comparator is usually limited only by the full swing of power supply.

5.2 Op-amp voltage comparator

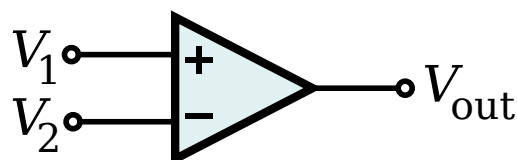

A simple op-amp comparator

An operational amplifier (op-amp) has a well balanced difference input and a very high gain. This parallels the characteristics of comparators and can be substituted in applications with low-performance requirements.^[4]

In theory, a standard op-amp operating in open-loop configuration (without negative feedback) may be used as a low-performance comparator. When the non-inverting input (V_+) is at a higher voltage than the inverting input (V_-), the high gain of the op-amp causes the output to saturate at the highest positive voltage it can output. When the non-inverting input (V_+) drops below the inverting input (V_-), the output saturates at the most negative voltage it can output. The op-amp's output voltage is limited by the supply voltage. An op-amp operating in a linear mode with negative feedback, using a balanced, split-voltage power supply, (powered by $\pm V_S$) has its transfer function typically written as: $V_{out} = A_o(V_1 - V_2)$. However, this equation may not be applicable to a comparator circuit which is non-linear and operates open-loop (no negative feedback)

In practice, using an operational amplifier as a comparator presents several disadvantages as compared to using a dedicated comparator.^[5]

1. Op-amps are designed to operate in the linear mode with negative feedback. Hence, an op-amp typically

has a lengthy recovery time from saturation. Almost all op-amps have an internal compensation capacitor which imposes **slew rate** limitations for high frequency signals. Consequently an op-amp makes a sloppy comparator with **propagation delays** that can be as long as tens of microseconds.

2. Since op-amps do not have any internal hysteresis, an external hysteresis network is always necessary for slow moving input signals.
3. The quiescent current specification of an op-amp is valid only when the feedback is active. Some op-amps show an increased quiescent current when the inputs are not equal.
4. A comparator is designed to produce well limited output voltages that easily interface with digital logic. Compatibility with digital logic must be verified while using an op-amp as a comparator.
5. Some multiple-section op-amps may exhibit extreme channel-channel interaction when used as comparators.
6. Many op-amps have back to back diodes between their inputs. Op-amp inputs usually follow each other so this is fine. But comparator inputs are not usually the same. The diodes can cause unexpected current through inputs.

5.3 Working

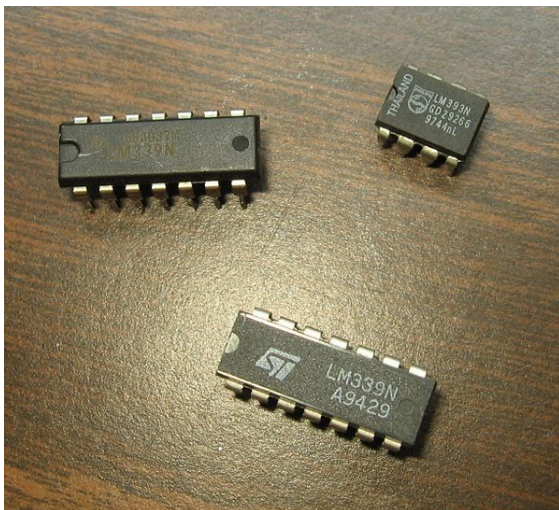

Several voltage comparator ICs

A dedicated voltage comparator will generally be faster than a general-purpose operational amplifier pressed into service as a comparator. A dedicated voltage comparator may also contain additional features such as an accurate, internal voltage reference, an adjustable hysteresis and a clock gated input.

A dedicated voltage comparator chip such as LM339 is designed to interface with a digital logic interface (to a **TTL** or a **CMOS**). The output is a binary state often used to interface real world signals to digital circuitry (see **analog to digital converter**). If there is a fixed voltage source from, for example, a DC adjustable device in the signal path, a comparator is just the equivalent of a cascade of amplifiers. When the voltages are nearly equal, the output voltage will not fall into one of the logic levels, thus analog signals will enter the digital domain with unpredictable results. To make this range as small as possible, the amplifier cascade is high gain. The circuit consists of mainly **Bipolar transistors**. For very high frequencies, the input **impedance** of the stages is low. This reduces the saturation of the slow, large **P-N junction bipolar transistors** that would otherwise lead to long recovery times. Fast small **Schottky diodes**, like those found in binary logic designs, improve the performance significantly though the performance still lags that of circuits with amplifiers using analog signals. Slew rate has no meaning for these devices. For applications in **flash ADCs** the distributed signal across eight ports matches the voltage and current gain after each amplifier, and resistors then behave as level-shifters.

The LM339 accomplishes this with an **open collector** output. When the inverting input is at a higher voltage than the non inverting input, the output of the comparator connects to the negative power supply. When the non inverting input is higher than the inverting input, the output is 'floating' (has a very high impedance to ground). The gain of op amp as comparator is given by this equation $V_{out}=V_{in}*A$

With a pull-up resistor and a 0 to +5 V power supply, the output takes on the voltages 0 or +5 and can interface with TTL logic:

$$V_{out} \leq V_{CC} \text{ when } V_{+} \geq V_{-} \text{ else } 0 .$$

5.4 Key specifications

While it is easy to understand the basic task of a comparator, that is, comparing two voltages or currents, several parameters must be considered while selecting a suitable comparator:

5.4.1 Speed and power

While in general comparators are “fast,” their circuits are not immune to the classic speed-power tradeoff. High speed comparators use transistors with larger aspect ratios and hence also consume more power.^[6] Depending on the application, select either a comparator with high speed or one that saves power. For example, nano-powered comparators in space-saving chip-scale packages (UCSP), DFN or SC70 packages such as **MAX9027**,

LTC1540, LPV7215, MAX9060 and MCP6541 are ideal for ultra-low-power, portable applications. Likewise if a comparator is needed to implement a relaxation oscillator circuit to create a high speed clock signal then comparators having few nano seconds of propagation delay may be suitable. ADCMP572 (CML output), LMH7220 (LVDS Output), MAX999 (CMOS output / TTL output), LT1719 (CMOS output / TTL output), MAX9010 (TTL output), and MAX9601 (PECL output) are examples of some good high speed comparators.

5.4.2 Hysteresis

A comparator normally changes its output state when the voltage between its inputs crosses through approximately zero volts. Small voltage fluctuations due to noise, always present on the inputs, can cause undesirable rapid changes between the two output states when the input voltage difference is near zero volts. To prevent this output oscillation, a small hysteresis of a few millivolts is integrated into many modern comparators.^[7] For example, the LTC6702, MAX9021 and MAX9031 have internal hysteresis desensitizing them from input noise. In place of one switching point, hysteresis introduces two: one for rising voltages, and one for falling voltages. The difference between the higher-level trip value (V_{TRIP+}) and the lower-level trip value (V_{TRIP-}) equals the hysteresis voltage (V_{HYST}).

If the comparator does not have internal hysteresis or if the input noise is greater than the internal hysteresis then an external hysteresis network can be built using positive feedback from the output to the non-inverting input of the comparator. The resulting Schmitt trigger circuit gives additional noise immunity and a cleaner output signal. Some comparators such as LMP7300, LTC1540, MAX931, MAX971 and ADCMP341 also provide the hysteresis control through a separate hysteresis pin. These comparators make it possible to add a programmable hysteresis without feedback or complicated equations. Using a dedicated hysteresis pin is also convenient if the source impedance is high since the inputs are isolated from the hysteresis network.^[8] When hysteresis is added then a comparator cannot resolve signals within the hysteresis band.

5.4.3 Output type

Because comparators have only two output states, their outputs are near zero or near the supply voltage. Bipolar rail-to-rail comparators have a common-emitter output that produces a small voltage drop between the output and each rail. That drop is equal to the collector-to-emitter voltage of a saturated transistor. When output currents are light, output voltages of CMOS rail-to-rail comparators, which rely on a saturated MOSFET, range closer to the rails than their bipolar counterparts.^[9]

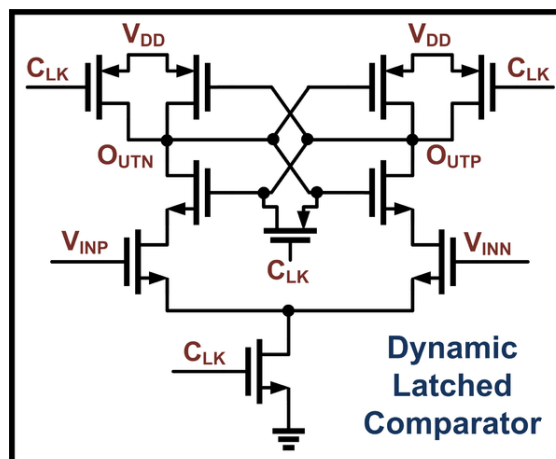

A Low Power CMOS Clocked Comparator

On the basis of outputs, comparators can also be classified as open drain or push-pull. Comparators with an open-drain output stage use an external pull up resistor to a positive supply that defines the logic high level. Open drain comparators are more suitable for mixed-voltage system design. Since the output is high impedance for logic level high, open drain comparators can also be used to connect multiple comparators on to a single bus. Push pull output does not need a pull up resistor and can also source current unlike an open drain output.

5.4.4 Internal reference

The most frequent application for comparators is the comparison between a voltage and a stable reference. Most comparator manufacturers also offer comparators in which a reference voltage is integrated on to the chip. Combining the reference and comparator in one chip not only saves space, but also draws less supply current than a comparator with an external reference.^[9] ICs with wide range of references are available such as MAX9062(200 mV reference), LT6700(400 mV reference), ADCMP350 (600 mV reference), MAX9025 (1.236 V reference), MAX9040 (2.048 V reference), TLV3012 (1.24 V reference) and TSM109 (2.5 V reference).

5.4.5 Continuous versus clocked

A continuous comparator will output either a “1” or a “0” any time a high or low signal is applied to its input and will change quickly when the inputs are updated. However, many applications only require comparator outputs at certain instances, such as in A/D converters and memory. By only strobing a comparator at certain intervals, higher accuracy and lower power can be achieved with a clocked (or dynamic) comparator structure, also called a latched comparator. Often latched comparators employ strong positive feedback for a “regeneration phase” when

a clock is high, and have a “reset phase” when the clock is low.^[10] This is in contrast to a continuous comparator, which can only employ weak positive feedback since there is no reset period.

5.5 Applications

Main article: [Comparator applications](#)

5.5.1 Null detectors

A null detector is one that functions to identify when a given value is zero. Comparators can be a type of amplifier distinctively for null comparison measurements. It is the equivalent to a very high gain amplifier with well-balanced inputs and controlled output limits. The circuit compares the two input voltages, determining the larger. The inputs are an unknown voltage and a reference voltage, usually referred to as v_u and v_r . A reference voltage is generally on the non-inverting input (+), while v_u is usually on the inverting input (-). (A circuit diagram would display the inputs according to their sign with respect to the output when a particular input is greater than the other.) The output is either positive or negative, for example ± 12 V. In this case, the idea is to detect when there is no difference between in the input voltages. This gives the identity of the unknown voltage since the reference voltage is known.

When using a comparator as a null detector, there are limits as to the accuracy of the zero value measurable. Zero output is given when the magnitude of the difference in the voltages multiplied by the gain of the amplifier is less than the voltage limits. For example, if the gain of the amplifier is 10^6 , and the voltage limits are ± 6 V, then no output will be given if the difference in the voltages is less than $6 \mu\text{V}$. One could refer to this as a sort of uncertainty in the measurement.^[11]

5.5.2 Zero-crossing detectors

For this type of detector, a comparator detects each time an ac pulse changes polarity. The output of the comparator changes state each time the pulse changes its polarity, that is the output is HI (high) for a positive pulse and LO (low) for a negative pulse squares the input signal.^[12]

5.5.3 Relaxation oscillator

A comparator can be used to build a relaxation oscillator. It uses both positive and negative feedback. The positive feedback is a Schmitt trigger configuration. Alone, the trigger is a bistable multivibrator. However, the slow negative feedback added to the trigger by the RC circuit

causes the circuit to oscillate automatically. That is, the addition of the RC circuit turns the hysteretic bistable multivibrator into an astable multivibrator.^[13]

5.5.4 Level shifter

This circuit requires only a single comparator with an open-drain output as in the LM393, TLV3011 or MAX9028. The circuit provides great flexibility in choosing the voltages to be translated by using a suitable pull up voltage. It also allows the translation of bipolar ± 5 V logic to unipolar 3 V logic by using a comparator like the MAX972.^[9]

5.5.5 Analog-to-digital converters

When a comparator performs the function of telling if an input voltage is above or below a given threshold, it is essentially performing a 1-bit quantization. This function is used in nearly all analog to digital converters (such as flash, pipeline, successive approximation, delta-sigma modulation, folding, interpolating, dual-slope and others) in combination with other devices to achieve a multi-bit quantization.^[14]

5.5.6 Window detectors

Comparators can also be used as window detectors. In a window detector, a comparator used to compare two voltages and determine whether a given input voltage is under voltage or over voltage.

5.6 See also

- Zero crossing threshold detector
- Digital comparator
- Current comparator
- Constant fraction discriminator
- Flash ADC
- Sorting network

This article incorporates public domain material from the General Services Administration document “Federal Standard 1037C”.

5.7 References

- [1] *LM111/LM211/LM311 datasheet*. Texas Instruments. August 2003. Retrieved 2014-07-02.

- [2] *LM139/LM239/LM339/LM2901/LM3302 datasheet*. Texas Instruments. August 2012. Retrieved 2014-07-02.
- [3] *LMH7322 datasheet*. Texas Instruments. March 2013. Retrieved 2014-07-02.
- [4] Malmstadt, Enke and Crouch, *Electronics and Instrumentation for Scientists*, The Benjamin/Cummings Publishing Company, Inc., 1981, ISBN 0-8053-6917-1, Chapter 5.
- [5] Ron Mancini, "Designing with comparators," EDN, March 29, 2001.
- [6] Rogenmoser, R.; Kaeslin, H, "The impact of transistor sizing on power efficiency in submicron CMOS circuits," *Solid-State Circuits, IEEE Journal of* Volume 32, Issue 7, Jul 1997 Page(s):1142–1145.
- [7] Ron Mancini, "Adding Hysteresis to comparators," EDN, May 3, 2001.
- [8] AN3616, Maxim Integrated Products, Adding Extra Hysteresis to Comparators.
- [9] AN886, Maxim Integrated Products, Selecting the Right Comparator.
- [10] Pedro M. Figueiredo, João C. Vital (2009). *Offset Reduction Techniques in High-Speed Analog-to-Digital Converters: Analysis, Design and Tradeoffs*. Springer. pp. 54–62. ISBN 978-1-4020-9715-7.
- [11] Malmstadt, Howard V.; Enke, Christie G.; Crouch, Stanley R. (January 1981), *Electronics and Instrumentation for Scientists*, The Benjamin/Cummings Publishing Co, pp. 108–110, ISBN 0-8053-6917-1
- [12] *Electronics and Instrumentation for Scientists*. Malmstadt, Enke, and Crouch, The Benjamin/Cummings Publishing Co., In., 1981, p.230.
- [13] Paul Horowitz and Winfield Hill: *The Art of Electronics*, Cambridge University Press, Second edition, Cambridge 1989, pp.284–285.
- [14] Phillip Allen and Douglas Holberg: *CMOS Analog Circuit Design*, Oxford University Press, Second edition, Oxford 2002.

5.8 External links

- IC Comparator reference page at home.cogeco.ca
- Comparator tutorial video with example circuits
- A Java based resistor value search tool for analysing an inverting comparator circuit with hysteresis

Chapter 6

Flash ADC

A **Flash ADC** (also known as a **Direct conversion ADC**) is a type of analog-to-digital converter that uses a linear voltage ladder with a comparator at each “rung” of the ladder to compare the input voltage to successive reference voltages. Often these reference ladders are constructed of many resistors; however modern implementations show that capacitive voltage division is also possible. The output of these comparators is generally fed into a digital encoder which converts the inputs into a binary value (the collected outputs from the comparators can be thought of as a unary value).

6.1 Benefits and drawbacks

Flash converters are extremely fast compared to many other types of ADCs which usually narrow in on the “correct” answer over a series of stages. Compared to these, a Flash converter is also quite simple and, apart from the analog comparators, only requires logic for the final conversion to binary.

For best accuracy often a track-and-hold circuit is inserted in front of the ADC input. This is needed for many ADC types (like successive approximation ADC), but for Flash ADCs there is no real need for this, because the comparators are the sampling devices.

A Flash converter requires a huge number of comparators compared to other ADCs, especially as the precision increases. A Flash converter requires $2^n - 1$ comparators for an n -bit conversion. The size, power consumption and cost of all those comparators makes Flash converters generally impractical for precisions much greater than 8 bits (255 comparators). In place of these comparators, most other ADCs substitute more complex logic and/or analog circuitry which can be scaled more easily for increased precision.

6.2 Implementation

Flash ADCs have been implemented in many technologies, varying from silicon based bipolar (BJT) and complementary metal oxide FETs (CMOS) technologies to

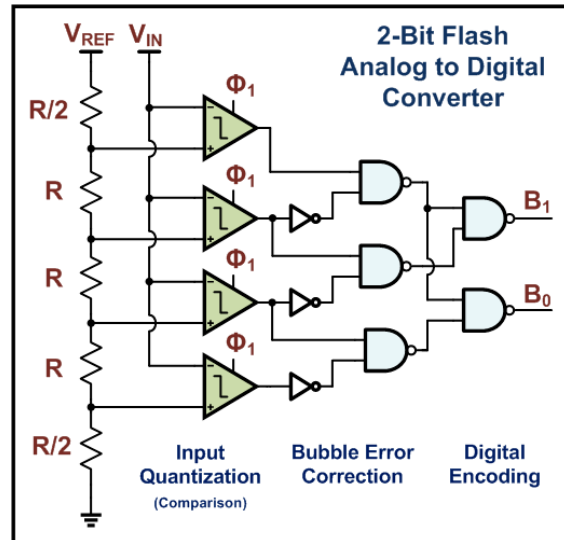

A 2-bit Flash ADC Example Implementation with Bubble Error Correction and Digital Encoding

rarely used III-V technologies. Often this type of ADC is used as a first medium-sized analog circuit verification.

The earliest implementations consisted of a reference ladder of well matched resistors connected to a reference voltage. Each tap at the resistor ladder is used for one comparator, possibly preceded by an amplification stage, and thus generates a logical '0' or '1' depending if the measured voltage is above or below the reference voltage of the resistor tap. The reason to add an amplifier is twofold: it amplifies the voltage difference and therefore suppresses the comparator offset, and the kick-back noise of the comparator towards the reference ladder is also strongly suppressed. Typically designs from 4-bit up to 6-bit, and sometimes 7-bit are produced.

Designs with power-saving capacitive reference ladders have been demonstrated. In addition to clocking the comparator(s), these systems also sample the reference value on the input stage. As the sampling is done at a very high rate, the leakage of the capacitors is negligible.

Recently, offset calibration has been introduced into flash ADC designs. Instead of high precision analog circuits (which increase component size to suppress variation)

comparators with relatively large offset errors are measured and adjusted. A test signal is applied and the offset of each comparator is calibrated to below the **LSB** size of the ADC.

Another improvement to many flash ADCs is the inclusion of digital error correction. When the ADC is used in harsh environments or constructed from very small integrated circuit processes, there is a heightened risk a single comparator will randomly change state resulting in a wrong code. Bubble error correction is a digital correction mechanism that will prevent a comparator that has, for example, tripped high from reporting logic high if it is surrounded by comparators that are reporting logic low.

6.3 Folding ADC

The number of comparators can be reduced somewhat by adding a folding circuit in front, making a so-called *folding ADC*. Instead of using the comparators in a Flash ADC only once, during a ramp input signal, the folding ADC re-uses the comparators multiple times. If a m -times folding circuit is used in an n -bit ADC, the actual number of comparator can be reduced from $2^n - 1$ to $\frac{2^n}{m}$ (there is always one needed to detect the range crossover). Typical folding circuits are, e.g., the Gilbert multiplier, or analog wired-or circuits.

6.4 Application

The very high sample rate of this type of ADC enable gigahertz applications like radar detection, wide band radio receivers, electronic test equipment, and optical communication links. More often the flash ADC is embedded in a large IC containing many digital decoding functions.

Also a small flash ADC circuit may be present inside a delta-sigma modulation loop.

Flash ADCs are also used in NAND flash memory, where up to 3 bits are stored per cell as 8 level voltages on floating gates.

6.5 References

- Analog to Digital Conversion
- Understanding Flash ADCs
- “Integrated Analog-to-Digital and Digital-to-Analog Converters”, R. van de Plassche, ADCs, Kluwer Academic Publishers, 1994.
- “A Precise Four-Quadrant Multiplier with Subnanosecond Response”, Barrie Gilbert, IEEE Journal of Solid-State Circuits, Vol. 3, No. 4 (1968), pp. 365–373

Chapter 7

Network analysis (electrical circuits)

“Circuit theory” redirects here. For other uses, see [Circuit \(disambiguation\)](#).

A network, in the context of electronics, is a collection of interconnected components. **Network analysis** is the process of finding the voltages across, and the currents through, every component in the network. There are many different techniques for calculating these values. However, for the most part, the applied technique assumes that the components of the network are all *linear*. The methods described in this article are only applicable to *linear* network analysis, except where explicitly stated.

7.1 Definitions

7.2 Equivalent circuits

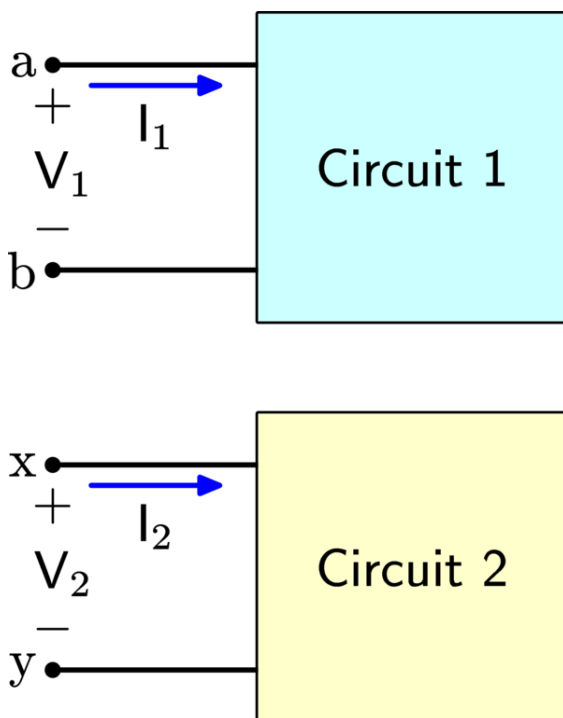

Main article: [equivalent impedance transforms](#)

A useful procedure in network analysis is to simplify the network by reducing the number of components. This can be done by replacing the actual components with other notional components that have the same effect. A particular technique might directly reduce the number of components, for instance by combining impedances in series. On the other hand it might merely change the form into one in which the components can be reduced in a later operation. For instance, one might transform a voltage generator into a current generator using Norton's theorem in order to be able to later combine the internal resistance of the generator with a parallel impedance load.

A **resistive circuit** is a circuit containing only resistors, ideal current sources, and ideal voltage sources. If the sources are constant (DC) sources, the result is a DC circuit. Analysis of a circuit consists of solving for the voltages and currents present in the circuit. The solution principles outlined here also apply to phasor analysis of AC circuits.

Two circuits are said to be **equivalent** with respect to a pair of terminals if the voltage across the terminals and current through the terminals for one network have the same relationship as the voltage and current at the terminals of the other network.

If $V_2 = V_1$ implies $I_2 = I_1$ for all (real) values of V_1 , then with respect to terminals ab and xy , circuit 1 and circuit 2 are equivalent.

The above is a sufficient definition for a one-port network. For more than one port, then it must be defined that the currents and voltages between all pairs of corresponding ports must bear the same relationship. For instance, star and delta networks are effectively three port networks and hence require three simultaneous equations to fully specify their equivalence.

7.2.1 Impedances in series and in parallel

Any two terminal network of impedances can eventually be reduced to a single impedance by successive applications of impedances in series or impedances in parallel.

Impedances in series: $Z_{eq} = Z_1 + Z_2 + \dots + Z_n$.

- Thévenin's theorem states that any two-terminal network can be reduced to an ideal voltage generator plus a series impedance.

7.3 Simple networks

Some very simple networks can be analysed without the need to apply the more systematic approaches.

7.3.1 Voltage division of series components

Main article: [voltage division](#)

Consider n impedances that are connected in **series**. The voltage V_i across any impedance Z_i is

$$V_i = Z_i I = \left(\frac{Z_i}{Z_1 + Z_2 + \dots + Z_n} \right) V$$

7.3.2 Current division of parallel components

Main article: [current division](#)

Consider n impedances that are connected in **parallel**. The current I_i through any impedance Z_i is

$$I_i = \left(\frac{\left(\frac{1}{Z_i} \right)}{\left(\frac{1}{Z_1} \right) + \left(\frac{1}{Z_2} \right) + \dots + \left(\frac{1}{Z_n} \right)} \right) I$$

for $i = 1, 2, \dots, n$.

Special case: Current division of two parallel components

$$I_1 = \left(\frac{Z_2}{Z_1 + Z_2} \right) I$$

$$I_2 = \left(\frac{Z_1}{Z_1 + Z_2} \right) I$$

7.4 Nodal analysis

Main article: [nodal analysis](#)

1. Label all **nodes** in the circuit. Arbitrarily select any node as reference.

2. Define a voltage variable from every remaining node to the reference. These voltage variables must be defined as voltage rises with respect to the reference node.
3. Write a **KCL** equation for every node except the reference.
4. Solve the resulting system of equations.

7.5 Mesh analysis

Main article: [mesh analysis](#)

Mesh — a loop that does not contain an inner loop.

1. Count the number of “window panes” in the circuit. Assign a mesh current to each window pane.
2. Write a **KVL** equation for every mesh whose current is unknown.
3. Solve the resulting equations

7.6 Superposition

Main article: [Superposition theorem](#)

In this method, the effect of each generator in turn is calculated. All the generators other than the one being considered are removed; either short-circuited in the case of voltage generators, or open circuited in the case of current generators. The total current through, or the total voltage across, a particular branch is then calculated by summing all the individual currents or voltages.

There is an underlying assumption to this method that the total current or voltage is a linear superposition of its parts. The method cannot, therefore, be used if non-linear components are present. Note that mesh analysis and node analysis also implicitly use superposition so these too, are only applicable to linear circuits. Superposition cannot be used to find total power consumed by elements even in linear circuits. Power varies according to the square of total voltage (or current) and the square of the sum is not generally equal to sum of the squares.

7.7 Choice of method

Choice of method^[2] is to some extent a matter of taste. If the network is particularly simple or only a specific current or voltage is required then ad-hoc application of some simple equivalent circuits may yield the answer without recourse to the more systematic methods.

- Superposition is possibly the most conceptually simple method but rapidly leads to a large number of

equations and messy impedance combinations as the network becomes larger.

- **Nodal analysis:** The number of voltage variables, and hence simultaneous equations to solve, equals the number of nodes minus one. Every voltage source connected to the reference node reduces the number of unknowns (and equations) by one.
- **Mesh analysis:** The number of current variables, and hence simultaneous equations to solve, equals the number of meshes. Every current source in a mesh reduces the number of unknowns by one. Mesh analysis can only be used with networks which can be drawn as a planar network, that is, with no crossing components.^[3]

7.8 Transfer function

A **transfer function** expresses the relationship between an input and an output of a network. For resistive networks, this will always be a simple real number or an expression which boils down to a real number. Resistive networks are represented by a system of simultaneous algebraic equations. However in the general case of linear networks, the network is represented by a system of simultaneous linear differential equations. In network analysis, rather than use the differential equations directly, it is usual practice to carry out a **Laplace transform** on them first and then express the result in terms of the Laplace parameter s , which in general is **complex**. This is described as working in the **s -domain**. Working with the equations directly would be described as working in the time (or t) domain because the results would be expressed as time varying quantities. The Laplace transform is the mathematical method of transforming between the s -domain and the t -domain.

This approach is standard in **control theory** and is useful for determining **stability** of a system, for instance, in an amplifier with feedback.

7.8.1 Two terminal component transfer functions

For two terminal components the transfer function, or more generally for non-linear elements, the **constitutive equation**, is the relationship between the current input to the device and the resulting voltage across it. The transfer function, $Z(s)$, will thus have units of impedance – ohms. For the three passive components found in electrical networks, the transfer functions are;

For a network to which only steady ac signals are applied, s is replaced with $j\omega$ and the more familiar values from ac network theory result.

Finally, for a network to which only steady dc is applied, s is replaced with zero and dc network theory applies.

7.8.2 Two port network transfer function

Transfer functions, in general, in control theory are given the symbol $H(s)$. Most commonly in electronics, transfer function is defined as the ratio of output voltage to input voltage and given the symbol $A(s)$, or more commonly (because analysis is invariably done in terms of sine wave response), $A(j\omega)$, so that;

$$A(j\omega) = \frac{V_o}{V_i}$$

The A standing for attenuation, or amplification, depending on context. In general, this will be a complex function of $j\omega$, which can be derived from an analysis of the impedances in the network and their individual transfer functions. Sometimes the analyst is only interested in the magnitude of the gain and not the phase angle. In this case the complex numbers can be eliminated from the transfer function and it might then be written as;

$$A(\omega) = \left| \frac{V_o}{V_i} \right|$$

Two port parameters

Main article: [Two-port network](#)

The concept of a two-port network can be useful in network analysis as a **black box** approach to analysis. The behaviour of the two-port network in a larger network can be entirely characterised without necessarily stating anything about the internal structure. However, to do this it is necessary to have more information than just the $A(j\omega)$ described above. It can be shown that four such parameters are required to fully characterise the two-port network. These could be the forward transfer function, the input impedance, the reverse transfer function (i.e., the voltage appearing at the input when a voltage is applied to the output) and the output impedance. There are many others (see the main article for a full listing), one of these expresses all four parameters as impedances. It is usual to express the four parameters as a matrix;

$$\begin{bmatrix} V_1 \\ V_0 \end{bmatrix} = \begin{bmatrix} z(j\omega)_{11} & z(j\omega)_{12} \\ z(j\omega)_{21} & z(j\omega)_{22} \end{bmatrix} \begin{bmatrix} I_1 \\ I_0 \end{bmatrix}$$

The matrix may be abbreviated to a representative element;

$$[z(j\omega)] \text{ or just } [z]$$

These concepts are capable of being extended to networks of more than two ports. However, this is rarely done in reality because, in many practical cases, ports are considered either purely input or purely output. If reverse direction transfer functions are ignored, a multi-port network can always be decomposed into a number of two-port networks.

Distributed components

Where a network is composed of discrete components, analysis using two-port networks is a matter of choice, not essential. The network can always alternatively be analysed in terms of its individual component transfer functions. However, if a network contains **distributed components**, such as in the case of a **transmission line**, then it is not possible to analyse in terms of individual components since they do not exist. The most common approach to this is to model the line as a two-port network and characterise it using two-port parameters (or something equivalent to them). Another example of this technique is modelling the carriers crossing the base region in a high frequency transistor. The base region has to be modelled as distributed resistance and capacitance rather than **lumped components**.

Image analysis

Main article: **Image impedance**

Transmission lines and certain types of filter design use the image method to determine their transfer parameters. In this method, the behaviour of an infinitely long cascade connected chain of identical networks is considered. The input and output impedances and the forward and reverse transmission functions are then calculated for this infinitely long chain. Although the theoretical values so obtained can never be exactly realised in practice, in many cases they serve as a very good approximation for the behaviour of a finite chain as long as it is not too short.

7.9 Non-linear networks

Most electronic designs are, in reality, non-linear. There is very little that does not include some semiconductor devices. These are invariably non-linear, the transfer function of an ideal semiconductor **p-n junction** is given by the very non-linear relationship;

$$i = I_o(e^{\frac{v}{VT}} - 1)$$

where;

- i and v are the instantaneous current and voltage.
- I_o is an arbitrary parameter called the reverse leakage current whose value depends on the construction of the device.
- VT is a parameter proportional to temperature called the thermal voltage and equal to about 25mV at room temperature.

There are many other ways that non-linearity can appear in a network. All methods utilising linear superposition will fail when non-linear components are present. There are several options for dealing with non-linearity depending on the type of circuit and the information the analyst wishes to obtain.

7.9.1 Constitutive equations

The diode equation above is an example of an **element constitutive equation** of the general form,

$$f(v, i) = 0$$

This can be thought of as a non-linear resistor. The corresponding constitutive equations for non-linear inductors and capacitors are respectively;

$$f(v, \varphi) = 0$$

$$f(v, q) = 0$$

where f is any arbitrary function, φ is the stored magnetic flux and q is the stored charge.

7.9.2 Existence, uniqueness and stability

An important consideration in non-linear analysis is the question of uniqueness. For a network composed of linear components there will always be one, and only one, unique solution for a given set of boundary conditions. This is not always the case in non-linear circuits. For instance, a linear resistor with a fixed current applied to it has only one solution for the voltage across it. On the other hand, the non-linear tunnel diode has up to three solutions for the voltage for a given current. That is, a particular solution for the current through the diode is not unique, there may be others, equally valid. In some cases there may not be a solution at all: the question of existence of solutions must be considered.

Another important consideration is the question of stability. A particular solution may exist, but it may not be stable, rapidly departing from that point at the slightest stimulation. It can be shown that a network that is absolutely stable for all conditions must have one, and only one, solution for each set of conditions.^[4]

7.9.3 Methods

Boolean analysis of switching networks

A switching device is one where the non-linearity is utilised to produce two opposite states. CMOS devices in digital circuits, for instance, have their output connected

to either the positive or the negative supply rail and are never found at anything in between except during a transient period when the device is actually switching. Here the non-linearity is designed to be extreme, and the analyst can actually take advantage of that fact. These kinds of networks can be analysed using **Boolean algebra** by assigning the two states (“on”/“off”, “positive”/“negative” or whatever states are being used) to the boolean constants “0” and “1”.

The transients are ignored in this analysis, along with any slight discrepancy between the actual state of the device and the nominal state assigned to a boolean value. For instance, boolean “1” may be assigned to the state of +5V. The output of the device may actually be +4.5V but the analyst still considers this to be boolean “1”. Device manufacturers will usually specify a range of values in their data sheets that are to be considered undefined (i.e. the result will be unpredictable).

The transients are not entirely uninteresting to the analyst. The maximum rate of switching is determined by the speed of transition from one state to the other. Happily for the analyst, for many devices most of the transition occurs in the linear portion of the devices transfer function and linear analysis can be applied to obtain at least an approximate answer.

It is mathematically possible to derive **boolean algebras** which have more than two states. There is not too much use found for these in electronics, although three-state devices are passingly common.

Separation of bias and signal analyses

This technique is used where the operation of the circuit is to be essentially linear, but the devices used to implement it are non-linear. A transistor amplifier is an example of this kind of network. The essence of this technique is to separate the analysis into two parts. Firstly, the dc biases are analysed using some non-linear method. This establishes the quiescent operating point of the circuit. Secondly, the small signal characteristics of the circuit are analysed using linear network analysis. Examples of methods that can be used for both these stages are given below.

Graphical method of dc analysis

In a great many circuit designs, the dc bias is fed to a non-linear component via a resistor (or possibly a network of resistors). Since resistors are linear components, it is particularly easy to determine the quiescent operating point of the non-linear device from a graph of its transfer function. The method is as follows: from linear network analysis the output transfer function (that is output voltage against output current) is calculated for the network of resistor(s) and the generator driving them. This will be a straight line (called the load line) and can readily be su-

perimposed on the transfer function plot of the non-linear device. The point where the lines cross is the quiescent operating point.

Perhaps the easiest practical method is to calculate the (linear) network open circuit voltage and short circuit current and plot these on the transfer function of the non-linear device. The straight line joining these two points is the transfer function of the network.

In reality, the designer of the circuit would proceed in the reverse direction to that described. Starting from a plot provided in the manufacturers data sheet for the non-linear device, the designer would choose the desired operating point and then calculate the linear component values required to achieve it.

It is still possible to use this method if the device being biased has its bias fed through another device which is itself non-linear – a diode for instance. In this case however, the plot of the network transfer function onto the device being biased would no longer be a straight line and is consequently more tedious to do.

Small signal equivalent circuit

This method can be used where the deviation of the input and output signals in a network stay within a substantially linear portion of the non-linear devices transfer function, or else are so small that the curve of the transfer function can be considered linear. Under a set of these specific conditions, the non-linear device can be represented by an equivalent linear network. It must be remembered that this equivalent circuit is entirely notional and only valid for the small signal deviations. It is entirely inapplicable to the dc biasing of the device.

For a simple two-terminal device, the small signal equivalent circuit may be no more than two components. A resistance equal to the slope of the v/i curve at the operating point (called the dynamic resistance), and tangent to the curve. A generator, because this tangent will not, in general, pass through the origin. With more terminals, more complicated equivalent circuits are required.

A popular form of specifying the small signal equivalent circuit amongst transistor manufacturers is to use the two-port network parameters known as **[h] parameters**. These are a matrix of four parameters as with the **[z]** parameters but in the case of the **[h]** parameters they are a hybrid mixture of impedances, admittances, current gains and voltage gains. In this model the three terminal transistor is considered to be a two port network, one of its terminals being common to both ports. The **[h]** parameters are quite different depending on which terminal is chosen as the common one. The most important parameter for transistors is usually the forward current gain, h_{21} , in the common emitter configuration. This is designated h_{fe} on data sheets.

The small signal equivalent circuit in terms of two-port

parameters leads to the concept of dependent generators. That is, the value of a voltage or current generator depends linearly on a voltage or current elsewhere in the circuit. For instance the $[z]$ parameter model leads to dependent voltage generators as shown in this diagram;

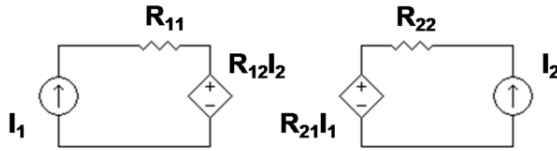

$[z]$ parameter equivalent circuit showing dependent voltage generators

There will always be dependent generators in a two-port parameter equivalent circuit. This applies to the $[h]$ parameters as well as to the $[z]$ and any other kind. These dependencies must be preserved when developing the equations in a larger linear network analysis.

Piecewise linear method

In this method, the transfer function of the non-linear device is broken up into regions. Each of these regions is approximated by a straight line. Thus, the transfer function will be linear up to a particular point where there will be a discontinuity. Past this point the transfer function will again be linear but with a different slope.

A well known application of this method is the approximation of the transfer function of a pn junction diode. The actual transfer function of an ideal diode has been given at the top of this (non-linear) section. However, this formula is rarely used in network analysis, a piecewise approximation being used instead. It can be seen that the diode current rapidly diminishes to $-I_0$ as the voltage falls. This current, for most purposes, is so small it can be ignored. With increasing voltage, the current increases exponentially. The diode is modelled as an open circuit up to the knee of the exponential curve, then past this point as a resistor equal to the bulk resistance of the semiconducting material.

The commonly accepted values for the transition point voltage are 0.7V for silicon devices and 0.3V for germanium devices. An even simpler model of the diode, sometimes used in switching applications, is short circuit for forward voltages and open circuit for reverse voltages.

The model of a forward biased pn junction having an approximately constant 0.7V is also a much used approximation for transistor base-emitter junction voltage in amplifier design.

The piecewise method is similar to the small signal method in that linear network analysis techniques can only be applied if the signal stays within certain bounds. If the signal crosses a discontinuity point then the model is no longer valid for linear analysis purposes. The model

does have the advantage over small signal however, in that it is equally applicable to signal and dc bias. These can therefore both be analysed in the same operations and will be linearly superimposable.

7.9.4 Time-varying components

In linear analysis, the components of the network are assumed to be unchanging, but in some circuits this does not apply, such as sweep oscillators, voltage controlled amplifiers, and variable equalisers. In many circumstances the change in component value is periodic. A non-linear component excited with a periodic signal, for instance, can be represented as periodically varying *linear* component. Sidney Darlington disclosed a method of analysing such periodic time varying circuits. He developed canonical circuit forms which are analogous to the canonical forms of Ronald Foster and Wilhelm Cauer used for analysing linear circuits.^[5]

7.10 See also

- Bartlett's bisection theorem
- Equivalent impedance transforms
- Kirchhoff's circuit laws
- Mesh analysis
- Millman's Theorem
- Ohm's law
- Reciprocity theorem
- Resistive circuit
- Series and parallel circuits
- Tellegen's theorem
- Two-port network
- Wye-delta transform
- Symbolic circuit analysis

7.11 References

- [1] Belevitch V (May 1962). "Summary of the history of circuit theory". *Proceedings of the IRE* **50** (5): 849. doi:10.1109/JRPROC.1962.288301. cites "IRE Standards on Circuits: Definitions of Terms for Linear Passive Reciprocal Time Invariant Networks, 1960". *Proceedings of the IRE* **48** (9): 1609. September 1960. doi:10.1109/JRPROC.1960.287676.to justify this definition.
- Sidney Darlington Darlington S (1984). "A history of network synthesis and filter theory for circuits composed of

resistors, inductors, and capacitors”. *IEEE Trans. Circuits and Systems* **31** (1): 4.

follows Belevitch but notes there are now also many colloquial uses of “network”.

- [2] Nilsson, J W, Riedel, S A (2007). *Electric Circuits* (8th ed.). Pearson Prentice Hall. pp. 112–113. ISBN 0-13-198925-1.
- [3] Nilsson, J W, Riedel, S A (2007). *Electric Circuits* (8th ed.). Pearson Prentice Hall. p. 94. ISBN 0-13-198925-1.
- [4] Ljiljana Trajković, “Nonlinear circuits”, *The Electrical Engineering Handbook* (Ed: Wai-Kai Chen), pp.79-81, Academic Press, 2005 ISBN 0-12-170960-4
- [5] US patent 3265973, Sidney Darlington, Irwin W. Sandberg, “Synthesis of two-port networks having periodically time-varying elements”, issued 1966-08-09

7.12 External links

- [Circuit Analysis Techniques](#) — includes node/mesh analysis, superposition, and thevenin/norton transformation
- [Nodal Analysis of Op Amp Circuits](#)
- [Analysis of Resistive Circuits](#)
- [Circuit Analysis Related Laws, Examples and Solutions](#)
- Sameen Ahmed Khan, Set Theoretic Approach to Resistor Networks, *Physics Education*, Volume 29, No. 4, Article Number: 5 (October-December 2013).

7.13 Text and image sources, contributors, and licenses

7.13.1 Text

- Resistor** *Source:* <http://en.wikipedia.org/wiki/Resistor?oldid=650268018> *Contributors:* AxelBoldt, Ap, Csx, Andre Engels, Christian List, Aldie, Matusz, Ray Van De Walker, SimonP, Waveguy, Heron, Patrick, RTC, Tim Starling, Mahjongg, Liftarn, Karada, Delirium, Alfio, CesarB, Ahoerstemeier, Cyp, Theresa knott, Darkwind, Glenn, Bogdangiusca, Nikai, Eszett, Timwi, Reddi, Zoicon5, Omegatron, Ed g2s, Wilbern Cobb, Chrisjj, Robbot, Hankwang, Tonsopcs, Leonard, Smith, Romanm, PxT, Ojigiri, Robinh, Xanzzibar, Cyrius, Pengo, Alan Liefting, Giftlite, Everyking, Perl, Markus Kuhn, Leonard G., Joe Sewell, Brockert, Bobblewik, Tagishsimon, Supachikn, StuartH, Chowbok, Antandrus, Mako098765, DragonflySixtyseven, Glogger, Gauss, Icairns, GeoGreg, Vishahu, TobinFricke, Ojw, Abdull, Discospinster, Rich Farmbrough, ArnoldReinhold, Alistair1978, Quistnix, Pavel Vozenilek, Paul August, ESkog, Plugwash, Patrickov, El C, Jd waverly, Haxwell, Art LaPella, RoyBoy, Bobo192, NetBot, AnyFile, Harald Hansen, Smalljim, Matt Britt, Colin Douglas Howell, Jojit fb, Kjkolb, Nk, Larry V, Sam Korn, Haham hanuka, Hooperblood, Nsaa, Ranveig, Red Winged Duck, Alansohn, Jic, Atlant, M7, Zippanova, Comrade009, Theodore Kloba, Wdfarmer, Snowolf, Velella, Wtshymanski, RainbowOfLight, Shoefly, Kusma, Carlos Quesada, DV8 2XL, Gene Nygaard, Kinema, HenryLi, Nilloc, Unixxx, Begemotv2718, Jeffrey O. Gustafson, Woohookitty, Mindmatrix, Pol098, Joels341, Stixpjr, Frankie1969, CPES, Gimboid13, PeregrineAY, FreplySpang, Rjwilmsi, Seidenstud, George Burgess, RobertDahlstrom, SeanMack, Brighterorange, Bratch, Yamamoto Ichiro, Fish and karate, FuelWagon, FlaBot, Jeepo, EPAstor, Shultzc, EmielMols, Alfred Centauri, Lmatt, Zotel, King of Hearts, Jidan, Chobot, Antilived, Krishnavedala, Bgwhite, DerrickOswald, YurikBot, Wavelength, RobotE, Jimp, Phantomsteve, Spudbeach, JabberWok, Ukdragon37, Hydrargyrum, Stephenb, Shaddack, Guiltyspark343, Shanel, SEWilcoBot, Borbrav, Srinivasasha, RazorICE, InvaderJim42, Mikeblas, DeadEyeArrow, Jeh, Blowdart, Oliverdl, SamuelRiv, Searchme, Richardcavell, FF2010, Uwezi, Light current, 21655, Phgao, Tabby, Nkendrick, DGaw, Mike1024, Allens, JSC ltd, Snaxe920, GrinBot, Jknacnud, Sbyrnes321, Teo64x, Neier, KnightRider, Dancraggs, SmackBot, Tarret, Bggoldie, Unyoyega, Thorseth, Cessator, Ohnoitsjamie, Hugo-cs, Lindosland, Chris the speller, Michbich, Oblemboy, CrookedAsterisk, Sirex98, Thumperward, Oli Filth, Papa November, Astaroth5, Ruffelo, Audriusa, Ian Burnet, Rifleman, Can't sleep, clown will eat me, Милан Јелисавчић, TheGerm, Ateş, Geekboy72, JonHarder, VMS Mosaic, RedHillian, CanDo, Yrral, M jurrens, DMacks, N Shar, Where, Mion, FelisLeo, Ohconfucius, SashatoBot, KLLvr283, Lao-geodritt, Dicklyon, Mets501, EdC, Quodfui, Matthew Kornya, Pi, Daniel5127, Atomobot, Electron20, Jpeguero, Sir Vicious, Ilikefood, Zureks, Pottsy123, Shoez, Jcoffland, W1tgf, Gatorosa, Requestion, MrFish, Kar403, Karimarie, Mblumber, Nbound, Altaphon, Meno25, Gogo Dodo, Tawkerbot4, DumbBOT, Viridae, Omicronpersei8, Ebraminio, Cinderblock63, Ozguy89, Serych, Epb123, Mojo Hand, John254, Neilajh, Gerry Ashton, Leon7, Ajo Mama, Matty!, Ketter, AntiVandalBot, Edokter, Dinferno, Spencer, Spartaz, Golgofrinchian, Deadbeef, JAnDbot, Pp0u016d, MER-C, Jddriessen, CosineKitty, Edwin ok, Magioladitis, VoABot II, JamesBWatson, Snthaker, Nikevich, Schily, Aka042, Carlsonmark, Catgut, Daarznicks, Virtlink, Americanhero, Allstarecho, User A1, Vssun, Calltech, Wderousse, Outlook, Dantman, DancingPenguin, MartinBot, Raymondoy, Sigmundg, Rettetast, Jonathan Hall, Nono64, GrahamDavies, Sephers, LedgendGamer, Tgeairn, J.delaney, Pharaoh of the Wizards, Peter Chastain, Dispenser, DarkFalls, Slrdtm, Falcon866, NewEnglandYankee, Suckindiesel, Sciport, Guitarlesson, Cmichael, Zhelp, Cometstyles, WJBscribe, Tchoutka, Uhai, Magatouche, Gaurav joseph, Scwerllguy, Useight, David.lecomte, Xiahou, Squids and Chips, Funandtrvl, Deor, VolkovBot, Lordmontu, Asnr 6, Jeff G., JohnBlackburne, Holme053, Constant314, EchoBravo, Alberon, Philip Trueman, TXiKiBoT, Qureus1, Hqb, Lordvolton, Retiono Virginian, Anna Lincoln, Dendodge, Zolot, LeaveSleaves, DarkFuture, PDFbot, Inductiveload, Dragon587, Enigmaman, Sarc37, Wolfrock, SQL, Synthebot, Jason Leach, Enviroboy, Davidvane, Spinningspark, Atreusk, Cindamuse, AlleborgoBot, Kbrose, JDHeinzmann, SieBot, Scarian, Gerakibot, Viskonsas, Matthew Yeager, Lucasbfrbot, Yintan, Msadaghd, Crm123, VampireBaru, Hoagg, Bentogoa, A. Carty, Xxrambo, Rocknroll-suicide, Poindexter Propellerhead, Lazyfishnet, IdreamofJeanie, Kudret abi, GeOrge359, StaticGull, Capitalismojo, Unique ragazzo, Djhammond, Felizdenovo, Precious Roy, Denisarona, Beemer69, Tuntable, Loren.wilton, De728631, ClueBot, Binksternet, GorillaWarfare, Khaleghian, CarolSpears, The Thing That Should Not Be, Ggia, AerospaceEngr, Mild Bill Hiccup, Edlerk, Thegeneralguy, Momentofinertia, Excirial, Jusdafax, TonyBallioni, Hardkrash, Arjayay, Wstorr, Aitias, Zootboy, Versus22, Moonlit Knight, Berean Hunter, Ginbot86, DumZiBoT, XLinkBot, Kyz 97, MarvinPelfer, Rror, Interferometrist, Skarebo, Madmike159, Udt-21, Karpouzi, Iranway, Mojska, Owl order, Nikhilb239, Addbot, Cxz111, Mortense, Bboe, Jojhutton, Fyrael, Olli Niemitalo, Metsavend, CanadianLinuxUser, Cst17, Download, Roux, Favonian, 5 albert square, Delphi234, Bavgang123, Tide rolls, MuZemike, Luckas-bot, Numikasi, Yobot, Fragggle81, II MusLiM HyBRiD II, Amirobot, MadMan2021, Omega99, THEN WHO WAS PHONE?, Mattia Luigi Nappi, KamikazeBot, Backtothetmacman32, Eric-Wester, Tempodivalse, CHUCKisGOD, Aliens are fun!!!!, AnomieBOT, KDS4444, Quangbao, Ravikant nit, Jim1138, Hat'nCoat, Piano non troppo, RBM 72, Aditya, Realgigabyte, MaterialsScientist, 4441gh, Citation bot, Tristantech, Felyza, Frankenpuppy, Neurol-ysis, Xqbot, Iadrian yu, Capricorn42, Miracleworker5263, Minnijazzjyade, Whipple11, Yoconst, GrouchoBot, Nedim Ardoğa, Sophus Bie, Shadowjams, Dakane2, Depictionimage, Prari, FrescoBot, Chugachuga, Furshur, Paco1976, Ecegovac, Kenny.Yang, BenzolBot, Rjwiki09, Oalp1003, Pinethicket, Boulaur, אֶלְיָהוּ, Rambo111, Nikey101, Salvidrim!, Lineslarge, Merlion444, December21st2012Freak, Jauhienij, Utility Monster, Abc518, Double sharp, كاشف عرقى, SchreyP, Uriburu, Vrenator, Reaper Eternal, Seahorseruler, Nascar1996, Minimac, DARTH SIDIOUS 2, Mean as custard, Skamecrazy123, EmausBot, Racexr11, GoingBatty, Hossammandour, Challisrussia, Wikipelli, Fæ, Lindseyrose, Trinidad, 1234r00t, H3llBot, EWikist, BrianSfinasSSI, Tolly4bolly, Sbmeirow, Tomásdearg92, Etugam, Anonimski, Autoerrant, Carmichael, Cupaxtai, Itaharesay, RockMagnetist, Maminov2, Capgunslinger, ClueBot NG, Smtchahal, Matthias-paul, Lanthanum-138, Frietjes, Jakuzem, 10v1walsha, Widr, Vortex112, Karthik262399, Sameenahmedkhan, Helpful Pixie Bot, Minderbart1, Pliu88, Wbm1058, Lowercase sigmabot, AntonioSajonia, Piguy101, Yowanvista, Alexey Villarreal, Dave 3740, Tsopatsopa, Glacial-fox, Chip123456, Funfun2333, ChrisGualtieri, GoShow, Embrittled, Chromastone1998, Raptormega123, Mediran, Kharz2, Dextbot, Oldschool1970, Zikri hidayat, Lugia2453, MWikiOrg, Orlin.tel, Ajay.loveland.jr, Pdecalculus, Eyesnore, Tentinator, Auburnate, John Blair76, Peter Sendtown, Tanujkumarpandey, Buntybhai, Ginsuloft, 72dodgerpress, Y13bakerm, JaconaFrere, Cricetone, JREling1, Bat-ManFascination, JaunJimenez, Trackteur, Owais Khursheed, Nodleh, Jelabon123, Qdavis, Akhil.A.L, Masteerr, Gouravd, JoJMasterRace, JoJMasterRace, Pitchcapper, Sytgod and Anonymus: 858
- Electronic color code** *Source:* <http://en.wikipedia.org/wiki/Electronic%20color%20code?oldid=646742154> *Contributors:* Jeronimo, Heron, RTC, LenBudney, SGBailey, Chinju, Minesweeper, Ahoerstemeier, Glenn, Samw, Etaoin, Reddi, Dysprosia, Zoicon5, Radijon, Omegatron, Ed g2s, Topbanana, Robbot, Tonsopcs, Wikibot, Pengo, Dina, Alan Liefting, Karn, Markus Kuhn, Wzww, Kmccoy, Rfl, Freakofnature, Rich Farmbrough, TedPavlic, Plugwash, RJHall, Lunaverse, Profeign, Hooperblood, WideArc, Alansohn, Corporal, Wtshymanski, Cburnett, Gene Nygaard, Drbreznjev, Brookie, Mindmatrix, Mu301, Pol098, Matijap, Edison, Rjwilmsi, Tim Eliseo, Lmatt, Alphachimp, Aluvus, Toffile, Hydrargyrum, Janke, Umeshmohan, Welsh, Jpbowen, Engineer Bob, Closedmouth, Bramble k, Ybbor, Amitverma, SmackBot, Reedy, McGeddon, KocjoBot, Daviddavid, Nil Einne, Bromskloss, Jushi, Pieoncar, Hugo-cs, Audriusa, JonHarder, VMS Mosaic, Wcleveland, Stefann, Doodle77, Hmoul, Colinbartlett, Loadmaster, Dicklyon, FortMax, Rouslan, Keycard, Coldfusion78, Blehfu, Simian1k, Cydebot, Altaphon, MC10, Xe4wv0, JustinForce, SpK, Pustelnik, Thijs!bot, D4g0thur, MDaniszewski, JustAGal, Stan-

nered, AntiVandalBot, Widefox, Jheiv, Edhuk, SiobhanHansa, Gekedo, Bongwarrior, DerHexer, Cjbarrett, Oren0, R sirahata, STBot, Jim.henderson, Akurn, Wookie2u, MJStadler, NewEnglandYankee, Apepper, KylieTastic, Thelagicbox, Bonadea, Funandrivl, Pixelstick, CWii, Asnr 6, Holme053, Barneca, Tr-the-maniac, Zed toocool, Vidtr, Cuddlyable3, Inductiveload, Mike4ty4, Mweissie, SieBot, Russ-Martin4154, Igor.grigorov, Alecjw, Flyer22, Agtaz, Chridd, Denisarona, Wdwd, Darsie from german wiki pedia, ClueBot, Dcblack56, The Thing That Should Not Be, Mrmikeb, Razimantv, Smtwkla, Sylvain Leroux, Eeekster, SpikeToronto, NuclearWarfare, Suyogaerspace, Wstorr, Elcap, XLinkBot, Ost316, Mifter, Addbot, Mortense, Willking1979, Tothwolf, Acklenx, Terabit, General Staal, PlankBot, Luckasbot, Gobbleswogger, Randolph Wait, AnomieBOT, Devargud, Motif user, Aghareep, ArthurBot, Sbesch, AvdN, Lasweeney, Ibjeremy, FrescoBot, SaturnineMind, Euc, SpacemanSpiff, Pinethicket, Fleetwil, Csciec, Snorror, Archphil, Lotje, The Utahraptor, Pkb2050, Jrw14493, Dewritech, RA0808, Noroi, K6ka, Wayne Slam, Tariq harr, AndyTheGrump, 28bot, ClueBot NG, MelbourneStar, Widr, Reify-tech, Sonusurendran, SimonZuckerbraun, Mn-imhotep, Exohhlauren, Mdann52, Khazar2, JRYon, SFK2, Sriharsh1234, Mokiecoke, Xstafelbach, Y13bakerm, Bilorv and Anonymous: 278

- **Surface-mount technology** *Source:* <http://en.wikipedia.org/wiki/Surface-mount%20technology?oldid=650310125> *Contributors:* Waveguy, Heron, Michael Hardy, Delirium, CesarB, Ronz, Julesd, Glenn, CAkira, Hankwang, Mfc, Alan Liefing, Brouhaha, DavidCary, Smurfix, Everyking, Fleminra, AndreKR, Khalid hassani, Zeimusu, DRE, Quota, Imroy, Pt, Evand, Homerjay, Share Bear, John Fader, Hooperbloom, Wdfarmer, Ronrkey, Wtshymanski, Cburnett, Gene Nygaard, Woohookitty, David Haslam, Pol098, Mbutts, Utuado, Borborygmus, Allen Moore, FlaBot, Wegsjac, Patentmat, Thunderbird, Efficacy, Mcleodm, Hydrargyrum, Shaddack, Bovineone, Pelago, Tony1, J.Holleman, Light current, Nicked, Nikkimaria, Zerodamage, Red Jay, Mike1024, Mais oui!, Katieh5584, Meegs, Veinor, SmackBot, Zephyris, Chris the speller, Bluebot, Thumperward, Janm67, ZyMOS, JonHarder, Wine Guy, Fuhghettaboutit, Lsjzl, Alsh, Euletz, CyrilB, Mabahj, Basjoosten, Dicklyon, DavidGrayson, MTSbot, MottyGlix, Screaming.people, Komeil, Mikebuetow, Atomobot, Ysette9, Chanik, Mikiemike, Cxw, Zureks, Gfbares, JettaMann, Jdmulloy, DavidMcCabe, Luccas, Christian75, Msnicki, Epr123, Al Lemos, Marek69, Smile a While, Electron9, James086, Leon7, Escarbot, Christopher1 s, AntiVandalBot, Mandra Oleka, Quintote, Behnam Ghiaseddin, Credema, Chill doubt, Ex-Nintendo Employee, JAndBot, Hut 8.5, Jahoe, Eintar, Magioladitis, ExFiler, Stigmj, Aka042, Indon, User A1, Moggie2002, Reguiiee, Avakar, R'n'B, CommonsDelinker, Mrataj, Krishna1612, Bushcarrot, JASEU, Cmdr Scolan, Homer Landskirty, EdgarDurbin, Andygock, Jirisundstrum, Sergivs-en, VolkovBot, Amikake3, Javiar, Rudi Loos, Philip Trueman, Mkcckc, NeighborJ, LeaveSleeves, Andy Dingley, Jpeeling, Spinningspark, Adrger, AlleborgoBot, Plan10, Hulzenga, Winchelsea, Mrmrmr1991, Happysailor, DaN PiCkFoRd, Doublehp, Dtvjho, Dipa1965, Nn123645, Asher196, ImageRemovalBot, WakingLili, Loren.wilton, ClueBot, Sunnysmt, Ninevoltz, DragonBot, Jacquesheuard, Ottawa4ever, La Pianista, Carto308, HumphreyW, Stickee, Noctibus, Alex Khimich, Addbot, Ramu50, Mortense, Some jerk on the Internet, Fluffernutter, Prxbl, Jordibatet, Oldmountains, Lightbot, Jarble, Ellery, Luckas-bot, Yobot, AnomieBOT, KDS4444, Jim1138, 5040RZ, Materialscientist, ArthurBot, Capricorn42, Cantoneshick, Birgitlanke, Owendarroch, RibotBOT, Bandjwet, Henk.muller, Ferentes, Globe Collector, BartłomiejB, Mik 0, Smta communications, Paly 1, Sky87 jun, Kiltedcueball, Haaribaer, Adronwiki, RjwilmsiBot, EmausBot, John of Reading, Dltwaddell, SMTAmember77, Dewritech, KrissN, Daonguyen95, AvicAWB, Wikfr, Laurasmithhp, Wingman417, Thine Antique Pen, Sbmeyrow, Sethupathy3e, Donner60, TS133, ClueBot NG, Carnaubo, Matthiaspaul, Tanbaum, DieSwartzPunkt, Asawula, Spuderator, Danim, For the stone, Theopolisme, Helpful Pixie Bot, BG19bot, Ramesh Ramaiah, PeterL9DO, KevinTough, Boxofmatches, 220 of Borg, BattyBot, YFdyh-bot, Khazar2, MadCowpoke, LarryKnight71, Ruby Murray, Peter Sendtown, Buntybhai, Ashishbuntybhaiya, Kaizentechnologies, Etek-gordon, Createsocial, Wehappen, Shailesh Patel at APC, U4205011 and Anonymous: 291
- **Operational amplifier** *Source:* <http://en.wikipedia.org/wiki/Operational%20amplifier?oldid=649509891> *Contributors:* Mav, The Anome, WillWare, Malcolm Farmer, Heron, Edward, RTC, Michael Hardy, Mahjongg, Wapcaplet, Julesd, Glenn, Ghewgill, GRAHAMUK, Bemoeial, Dysprosia, Andrewman327, Omegatron, Wernher, AnonMoos, AlexPlank, Hankwang, RedWolf, Donreed, Smithr, Pengo, Giftlite, DavidCary, Mintleaf, Inkling, Ds13, CyborgTosser, Leonard G., Frencheigh, Rpyle731, Mboverload, Foobar, Mike R, Aulis Eskola, DRE, Eranb, KeithTyler, Clemwang, M1ss1ontomars2k4, Adashiel, TedPavlic, ArnoldReinhold, Sn0wflake, ESKog, Plugwash, Dpotter, CanisRufus, Bdiesseldorff, Shanes, Bobo192, Nigelj, .:Ajlol.:, Foobaz, Hooperbloom, Musiphil, Neonumbers, Atlant, Keenan Pepper, Wtmitchell, Wtshymanski, Gene Nygaard, Alai, DSatz, Unixxx, Weyes, Woohookitty, Mindmatrix, Pol098, Cbdorset, CPES, Bmiboid13, Cataclysm, Msiddalingaiah, Snafflekid, Bvankuik, Sjakalle, Arabani, Alejo2083, Chris Prejnar, Ground Zero, Margosbot, Efficacy, Alfred Centauri, RexNL, Enon, Fresheneesz, Srleffler, YurikBot, Borgx, Gaius Cornelius, Rohitbd, Synaptitude, Grafen, 48v, Sparkinark, TDogg310, Voidxor, Supten, DeadEyeArrow, Elkman, Searchme, Bakkster Man, Light current, Super Rad!, Closedmouth, Mike1024, Mebden, Luk, Peranders, SmackBot, Igtorque, Thelukeeffect, Speight, Man with two legs, Jwestbrook, Gilliam, Lindosland, QEDquid, KD5TVI, Chris the speller, Bluebot, Oli Filth, EncMstr, Papa November, DHN-bot, FredStrauss, Audriusa, Royboycrashfan, Can't sleep, clown will eat me, LouScheffer, CanDo, TWINE006, Henning Makhholm, Evlekis, Bjesnar, Ohconfucius, Missamo80, Archimerged, Awbliven, JohnWittle, Antireconciler, CyrilB, Rogerbrent, Dicklyon, Novangelis, Kvng, Pgadfor, Yves-Laurent, Phil Christs, JForget, Circuit dreamer, WeggeBot, Myasuda, Anoneditor, Naspilot, Pylilium, ZHENG Jiajun, Viscious81, HermanFinster, Christian75, Khattab01, Raidfibre, Josemiotto, Editor at Large, Saintrain, Serych, Barticus88, Sunny sin2005, Electron9, Vasurak, Jonnie5, Nick Number, Escarbot, AntiVandalBot, Luna Santin, Seaphoto, Lovibond, MikeLynch, JAndBot, .K, CosineKitty, Magioladitis, Secret Squirrel, Acu7, Somebody2014, Hypergeek14, SwiftBot, Clankypup, Crunchy Numbers, First Harmonic, Allstarecho, Nodekeeper, Cocytus, Man-avbhardwaj, Mårten Berglund, Sigmundg, Glrx, CommonsDelinker, Jascii, J.delanoy, Jcurie, Sakhthivel30, Zen-in, Szzuk, SJP, Rumpelstiltskin223, TottyBot, Homer Landskirty, Pmoseley, Red Thrush, VolkovBot, ICE77, Philip Trueman, DoorsAjar, Draurbilla, Ianr44, Bizarro Bull, Inductiveload, Andy Dingley, Spinningspark, SieBot, Caltas, Charles.small, Roy hu, Jjwilkinson, Jp314159, Opamp, Bentogoa, M Puddick, OsamaBinLogin, Evaluator, Faradayplank, PHermans, OscarJuan, PerryTachett, ClueBot, Smart Viral, Binksternet, ArthurOgawa, Mild Bill Hiccup, Srinivasbt, Alexbot, Jusdafax, Brews ohare, Sldghmmr, La Pianista, Wstorr, Aitias, Johnuniq, SoxBot III, Analogkidr, Salam32, Alexius08, ZooFari, Skonieczny, Gggh, Addbot, Mortense, Some jerk on the Internet, Olli Niemitalo, Theleftorium, Sudeepa123, Ppj4, Download, Punkguitar, AnnaFrance, Favonian, LinkFA-Bot, Bruno gouveia rodrigues, Supavinnie, Eng general, OIEnglish, Pietrow, Zorrobot, RobertTanzi, Luckas-bot, Yobot, Ptbotgourou, Annomination, AnomieBOT, Paulthomas2, Jim1138, JackieBot, Piano non troppo, LiuyuanChen, Materialscientist, Citation bot, Akilaa, Xqbot, Sellyme, XZeroBot, دارةقول, Dprabhu, Maitchy, Endothermic, GliderMaven, FrescoBot, LucienBOT, Ong saluri, Berrinkursun, Anitauky, Wikigayburgers, Roman12345, Vhann, Gdje je nestala duša svijeta, I dream of horses, Jonesey95, Hoo man, Ezhuttukari, Mikespedia, Abhishekchavan79, Æneas, Dinamik-bot, Overjive, PleaseStand, DARTH SIDIOUS 2, Teravolt, Breezeboy, EmausBot, John of Reading, Kasper Meerts, Torturella, Tawisfikan, Solarra, Meht7860, Fæ, East of Borschov, Aflafla1, Thine Antique Pen, Rscprinter123, Sbmeyrow, Peterh5322, L Kensington, Danielop-NJITWILL, VictorianMutant, Petrb, Sudheerp99, ClueBot NG, Jaanus.kalde, Grottolese, Ulrich67, Muon, Iinvnt, Widr, Lain.cai, Oddbodz, Helpful Pixie Bot, Wbm1058, Czar44, Tony Tan 98, Sodaant, Minsbot, Yogirox234, Hghyux, MarinSwimmer, ChrisGualtieri, SD5bot, Dexbot, James12345, Visitor01, Babitaraora, Monkbot, Pcrengnr, TerryAlex, MorganBEAST, AntonKrugerAtUiowa, Madphysics, 6965REHAN, Sopogupta and Anonymous: 467
- **Comparator** *Source:* <http://en.wikipedia.org/wiki/Comparator?oldid=649717433> *Contributors:* Heron, Edward, Ahoerstemeier, Glenn, Smack, Schneelocke, Omegatron, Dbroadwell, Stuuf, Jaan513, Discospinster, Sietse Snel, Hooperbloom, Andrewpmk, Cburnett, Jannex,

Matthew Platts, Mandarax, Maxim Razin, Arnero, Crazycomputers, Stassats, Guerberj, Katieh5584, Bmearns, Lindosland, Bluebot, Daydreamer302000, Af1218, Barney Stratford, S Roper, Jeff Wheeler, Paul Rako, Avé, 16@r, Dicklyon, Daharde, Chetvorno, Mikiemike, Circuit dreamer, TAB, Thijs!bot, CosineKitty, Adilsm, Scott9, R'n'B, Amikake3, Grantdj, Miwanya, Inductiveload, AlleborgoBot, Flyer22, Sokari, ClueBot, The Thing That Should Not Be, Optics guy07, VQuakr, Mild Bill Hiccup, Somno, Three-quarter-ten, ChardonnayNimeque, PixelBot, SpikeToronto, Analogkidr, Addbot, Mortense, Yobot, Xqbot, NSK Nikolaos S. Karastathis, FrescoBot, Febert, Smurfettekla, Berrinkursun, Cannolis, I dream of horses, Calmer Waters, Chotugubbi, Eguru37, Wikieditorz, Reconsider the static, EmausBot, ZéroBot, East of Borschov, Derekleungszhei, ChuispastonBot, ClueBot NG, Helpful Pixie Bot, CitationCleanerBot, BattyBot, Jaspriitsgill, Imneerajgarg3, Monkbot, Ksumatrob and Anonymous: 111

- **Flash ADC** *Source:* <http://en.wikipedia.org/wiki/Flash%20ADC?oldid=649550173> *Contributors:* Cnwb, Kinema, Sherool, Guerberj, EAdherhold, Bmearns, Bluebot, JohnI, Bwpach, Iridescent, CmdrObot, Wsmarz, Thijs!bot, Jim.henderson, Sharoneditha, ELLAPRISCI, Squids and Chips, Reelrt, SlipperyHippo, Wdwd, ChardonnayNimeque, Addbot, HerculeBot, Overjive, Dewritech, ChuispastonBot, Opa-Pilot and Anonymous: 19
- **Network analysis (electrical circuits)** *Source:* [http://en.wikipedia.org/wiki/Network%20analysis%20\(electrical%20circuits\)?oldid=635274987](http://en.wikipedia.org/wiki/Network%20analysis%20(electrical%20circuits)?oldid=635274987) *Contributors:* SimonP, Heron, Michael Hardy, Charles Matthews, Omegatron, Prara, Dbenbenn, Semenka, Abdull, Stepp-Wulf, Alistair1978, PP Jewel, Plugwash, Billion, Nabla, Alberto Orlandini, Wshymanski, RJFJR, BillC, Cbdorsett, Mamling, Rjwilmsi, Koavf, Vegaswikian, Alfred Centauri, DVdm, Wavelength, RussBot, Gaius Cornelius, Vanished user 1029384756, Sergeroz, E Wing, Shyam, Katieh5584, SmackBot, The Photon, Yamaguchi, RDBrown, Greggwon, Rogerbrent, CmdrObot, Jurgen Hissen, Colinpan, Samprasanna.j, DerHexer, Jyrejoice, Mythealias, Enok.cc, Adavidb, TomyDuby, Mlewis000, VolkovBot, Beniek, Canaima, Tsi43318, Spinningspark, Doctorfluffy, Bpeps, ClueBot, Pakaraki, Mild Bill Hiccup, Arunsingh16, BOTarate, Aitias, DumZiBoT, Avoided, Mrball25, Addbot, MrOllie, Themfromspace, Rogger.Ferguson, SlothMcCarty, Materialsscientist, Xqbot, Lil chef1, Hpmemproject, Undsoweiter, FrescoBot, FoxBot, SchreyP, Tbhotch, EmausBot, GoingBatty, Hhhippo, ZéroBot, Yazaq, Rspence1234, 28bot, ClueBot NG, Satellizer, Sameenahmedkhan, Sh4rk89, Helpful Pixie Bot, Wbm1058, CitationCleanerBot, Salvador85, Quant18, Alexmailbox100, Rusmr1, Reatlas, Monkbot and Anonymous: 99

7.13.2 Images

- **File:0-ohm.jpg** *Source:* <http://upload.wikimedia.org/wikipedia/commons/f/fc/0-ohm.jpg> *License:* Public domain *Contributors:* Originally from en.wikipedia; description page is/was here. *Original artist:* Original uploader was Agapetos at en.wikipedia
- **File:2.26_kilo-ohm_precision_resistor.jpg** *Source:* http://upload.wikimedia.org/wikipedia/commons/d/d9/2.26_kilo-ohm_precision_resistor.jpg *License:* CC0 *Contributors:* Own work *Original artist:* Janke
- **File:28_pin_MLP_integrated_circuit.jpg** *Source:* http://upload.wikimedia.org/wikipedia/commons/2/23/28_pin_MLP_integrated_circuit.jpg *License:* Public domain *Contributors:* Photographed by User:Mike1024 *Original artist:* User Mike1024 on en.wikipedia
- **File:3_Resistors.jpg** *Source:* http://upload.wikimedia.org/wikipedia/commons/e/e3/3_Resistors.jpg *License:* CC BY-SA 2.5 *Contributors:* Own work *Original artist:* Afrank99
- **File:4-Band_Resistor.svg** *Source:* http://upload.wikimedia.org/wikipedia/commons/6/6e/4-Band_Resistor.svg *License:* Public domain *Contributors:* Made in Inkscape *Original artist:* jjbeard
- **File:Abcd-parameter_button.svg** *Source:* http://upload.wikimedia.org/wikipedia/en/9/94/Abcd-parameter_button.svg *License:* CC-BY-SA-3.0 *Contributors:* Self created using Inkscape
Original artist:
SpinningSpark
- **File:Admittance_button.svg** *Source:* http://upload.wikimedia.org/wikipedia/en/a/a4/Admittance_button.svg *License:* CC-BY-SA-3.0 *Contributors:* Self created using Inkscape
Original artist:
SpinningSpark
- **File:Ambox_important.svg** *Source:* http://upload.wikimedia.org/wikipedia/commons/b/b4/Ambox_important.svg *License:* Public domain *Contributors:* Own work, based off of Image:Ambox scales.svg *Original artist:* Dsmurat (talk · contribs)
- **File:Blank_button.svg** *Source:* http://upload.wikimedia.org/wikipedia/en/9/98/Blank_button.svg *License:* CC-BY-SA-3.0 *Contributors:* Self created using Inkscape
Original artist:
SpinningSpark
- **File:Capacitor_button.svg** *Source:* http://upload.wikimedia.org/wikipedia/en/9/91/Capacitor_button.svg *License:* CC-BY-SA-3.0 *Contributors:* Self created using Inkscape
Original artist:
SpinningSpark
- **File:Carbon-resistor-TR212-1.jpg** *Source:* <http://upload.wikimedia.org/wikipedia/commons/d/d4/Carbon-resistor-TR212-1.jpg> *License:* CC BY-SA 3.0 *Contributors:* Own work *Original artist:* Shaddack
- **File:Circuit_equivalence.png** *Source:* http://upload.wikimedia.org/wikipedia/commons/6/67/Circuit_equivalence.png *License:* CC-BY-SA-3.0 *Contributors:* ? *Original artist:* ?
- **File:Commons-logo.svg** *Source:* <http://upload.wikimedia.org/wikipedia/en/4/4a/Commons-logo.svg> *License:* ? *Contributors:* ? *Original artist:* ?
- **File:Comparators_stuuf.jpg** *Source:* http://upload.wikimedia.org/wikipedia/commons/1/1d/Comparators_stuuf.jpg *License:* CC BY-SA 3.0 *Contributors:* Own work *Original artist:* Stuuf

- **File:Conductance_button.svg** *Source:* http://upload.wikimedia.org/wikipedia/en/9/9c/Conductance_button.svg *License:* CC-BY-SA-3.0 *Contributors:*
Self created using Inkscape
Original artist:
Spinningspark
- **File:Current_button.svg** *Source:* http://upload.wikimedia.org/wikipedia/en/e/e9/Current_button.svg *License:* CC-BY-SA-3.0 *Contributors:*
Self created using Inkscape
Original artist:
Spinningspark
- **File:Danotherm_HS50_power_resistor.jpg** *Source:* http://upload.wikimedia.org/wikipedia/commons/a/a1/Danotherm_HS50_power_resistor.jpg *License:* CC0 *Contributors:* { www.danotherm.dk } *Original artist:* Olli Niemitalo
- **File:Delta-Star_Transformation.svg** *Source:* http://upload.wikimedia.org/wikipedia/commons/1/18/Delta-Star_Transformation.svg *License:* Public domain *Contributors:* SVG Replacement for Image:Delta_Star_transformation.png *Original artist:* jjbeard
- **File:Delta-Y_button.svg** *Source:* http://upload.wikimedia.org/wikipedia/en/4/4d/Delta-Y_button.svg *License:* CC-BY-SA-3.0 *Contributors:*
Self created using Inkscape
Original artist:
Spinningspark
- **File:Discrete_opamp.png** *Source:* http://upload.wikimedia.org/wikipedia/commons/8/85/Discrete_opamp.png *License:* CC BY-SA 3.0 *Contributors:* Op Amp Applications Handbook *Original artist:* Analog Devices
- **File:Dual_button.svg** *Source:* http://upload.wikimedia.org/wikipedia/en/8/89/Dual_button.svg *License:* CC-BY-SA-3.0 *Contributors:*
Self created using Inkscape
Original artist:
Spinningspark
- **File:Dynamic_Comparator.png** *Source:* http://upload.wikimedia.org/wikipedia/commons/c/c1/Dynamic_Comparator.png *License:* CC BY-SA 3.0 *Contributors:* Transferred from en.wikipedia. *Original artist:* Guerberj at en.wikipedia
- **File:EIA_Capacitor_Color_Codes.jpg** *Source:* http://upload.wikimedia.org/wikipedia/commons/a/a2/EIA_Capacitor_Color_Codes.jpg *License:* CC BY-SA 3.0 *Contributors:* Own work *Original artist:* Wtshymanski
- **File:Elastance_button.svg** *Source:* http://upload.wikimedia.org/wikipedia/en/4/43/Elastance_button.svg *License:* CC-BY-SA-3.0 *Contributors:*
Self created using Inkscape
Original artist:
Spinningspark
- **File:Flash_ADC.png** *Source:* http://upload.wikimedia.org/wikipedia/commons/3/3a/Flash_ADC.png *License:* CC BY 3.0 *Contributors:*
Own work *Original artist:* Jon Guerber
- **File:G-parameter_button.svg** *Source:* http://upload.wikimedia.org/wikipedia/en/a/ae/G-parameter_button.svg *License:* CC-BY-SA-3.0 *Contributors:*
Self created using Inkscape
Original artist:
Spinningspark
- **File:Generic_741_pinout_top.png** *Source:* http://upload.wikimedia.org/wikipedia/commons/7/72/Generic_741_pinout_top.png *License:* CC BY-SA 3.0 *Contributors:* Own work by uploader (derived from other own (Creative Commons) work from uploader at http://www.tedpavlic.com/teaching/osu/ece209/support/part_pinouts.pdf) *Original artist:* TedPavlic
- **File:H-parameter_button.svg** *Source:* http://upload.wikimedia.org/wikipedia/en/a/ac/H-parameter_button.svg *License:* CC-BY-SA-3.0 *Contributors:*
Self created using Inkscape
Original artist:
Spinningspark
- **File:Half-completed_manual_soldering_of_surface_mount_MQFP_integrated_circuit.jpg** *Source:* http://upload.wikimedia.org/wikipedia/commons/6/6f/Half-completed_manual_soldering_of_surface_mount_MQFP_integrated_circuit.jpg *License:* Public domain *Contributors:* Transferred from en.wikipedia *Original artist:* Photo taken by Mike1024 at en.wikipedia
- **File:Hybrid_opamp.png** *Source:* http://upload.wikimedia.org/wikipedia/commons/8/84/Hybrid_opamp.png *License:* CC BY-SA 3.0 *Contributors:* Op Amp Applications Handbook *Original artist:* Analog Devices
- **File:Impedance_button.svg** *Source:* http://upload.wikimedia.org/wikipedia/en/1/11/Impedance_button.svg *License:* CC-BY-SA-3.0 *Contributors:*
Self created using Inkscape
Original artist:
Spinningspark
- **File:Inductor_button.svg** *Source:* http://upload.wikimedia.org/wikipedia/en/7/7e/Inductor_button.svg *License:* CC-BY-SA-3.0 *Contributors:*
Self created using Inkscape
Original artist:
Spinningspark

- **File:Inverting_Amplifier_Signal_Clippling.png** *Source:* http://upload.wikimedia.org/wikipedia/commons/9/9f/Inverting_Amplifier_Signal_Clippling.png *License:* CC0 *Contributors:* Own work *Original artist:* Super Rad!
- **File:Juki_KE-2080L_by_Megger.jpg** *Source:* http://upload.wikimedia.org/wikipedia/commons/4/49/Juki_KE-2080L_by_Megger.jpg *License:* CC BY 3.0 *Contributors:* <http://www.megger.com> *Original artist:* Megger Ltd.
- **File:K2-w_Vacuum_Tube_Op-amp.jpg** *Source:* http://upload.wikimedia.org/wikipedia/commons/1/15/K2-w_Vacuum_Tube_Op-amp.jpg *License:* CC BY-SA 3.0 *Contributors:* Own work *Original artist:* Bdieseldorff
- **File:KCL_button.svg** *Source:* http://upload.wikimedia.org/wikipedia/en/9/99/KCL_button.svg *License:* CC-BY-SA-3.0 *Contributors:* Self created using Inkscape
Original artist:
SpinningSpark
- **File:KTSU_resistors.jpg** *Source:* http://upload.wikimedia.org/wikipedia/commons/1/10/KTSU_resistors.jpg *License:* CC BY-SA 2.5 *Contributors:* ru.wikipedia *Original artist:* Сергей Филатов
- **File:KVL_button.svg** *Source:* http://upload.wikimedia.org/wikipedia/en/1/1d/KVL_button.svg *License:* CC-BY-SA-3.0 *Contributors:* Self created using Inkscape
Original artist:
SpinningSpark
- **File:LM741CN.jpg** *Source:* <http://upload.wikimedia.org/wikipedia/commons/9/95/LM741CN.jpg> *License:* CC0 *Contributors:* Own work *Original artist:* Olli Niemitalo
- **File:Merge-arrow.svg** *Source:* <http://upload.wikimedia.org/wikipedia/commons/a/aa/Merge-arrow.svg> *License:* Public domain *Contributors:* ? *Original artist:* ?
- **File:Millman_button.svg** *Source:* http://upload.wikimedia.org/wikipedia/en/4/44/Millman_button.svg *License:* CC-BY-SA-3.0 *Contributors:* Self created using Inkscape
Original artist:
SpinningSpark
- **File:Modular_opamp.png** *Source:* http://upload.wikimedia.org/wikipedia/commons/9/97/Modular_opamp.png *License:* CC BY-SA 3.0 *Contributors:* Op Amp Applications Handbook *Original artist:* Analog Devices
- **File:Norton_button.svg** *Source:* http://upload.wikimedia.org/wikipedia/en/4/4a/Norton_button.svg *License:* CC-BY-SA-3.0 *Contributors:* Self created using Inkscape
Original artist:
SpinningSpark
- **File:Nuvola_apps_ksim.png** *Source:* http://upload.wikimedia.org/wikipedia/commons/8/8d/Nuvola_apps_ksim.png *License:* LGPL *Contributors:* <http://icon-king.com> *Original artist:* David Vignoni / ICON KING
- **File:Odporová_dekáda_KURBELWIDERSTAND_(A).jpg** *Source:* http://upload.wikimedia.org/wikipedia/commons/b/b8/Odporov%C3%A1_dek%C3%A1da_KURBELWIDERSTAND_%28A%29.jpg *License:* CC0 *Contributors:* Own work *Original artist:* Qwertz0451
- **File:Ohm's_law_button.svg** *Source:* http://upload.wikimedia.org/wikipedia/en/8/8e/Ohm%27s_law_button.svg *License:* CC-BY-SA-3.0 *Contributors:* Self created using Inkscape
Original artist:
SpinningSpark
- **File:Old_Radio_Resistors.jpg** *Source:* http://upload.wikimedia.org/wikipedia/en/d/d4/Old_Radio_Resistors.jpg *License:* PD *Contributors:* ? *Original artist:* ?
- **File:Op-Amp_Comparator.svg** *Source:* http://upload.wikimedia.org/wikipedia/commons/0/0d/Op-Amp_Comparator.svg *License:* Public domain *Contributors:* Own work *Original artist:* Inductiveload
- **File:Op-Amp_Internal.svg** *Source:* http://upload.wikimedia.org/wikipedia/commons/0/0d/Op-Amp_Internal.svg *License:* Public domain *Contributors:* Own work *Original artist:* Inductiveload
- **File:Op-Amp_Inverting_Amplifier.svg** *Source:* http://upload.wikimedia.org/wikipedia/commons/4/41/Op-Amp_Inverting_Amplifier.svg *License:* Public domain *Contributors:* Own work *Original artist:* Inductiveload
- **File:Op-Amp_Non-Inverting_Amplifier.svg** *Source:* http://upload.wikimedia.org/wikipedia/commons/4/44/Op-Amp_Non-Inverting_Amplifier.svg *License:* Public domain *Contributors:* Own work *Original artist:* Inductiveload
- **File:Op-amp_open-loop_1.svg** *Source:* http://upload.wikimedia.org/wikipedia/commons/8/8e/Op-amp_open-loop_1.svg *License:* CC BY-SA 3.0 *Contributors:* my drawing *Original artist:* Ong saluri
- **File:Op-amp_symbol.svg** *Source:* http://upload.wikimedia.org/wikipedia/commons/9/97/Op-amp_symbol.svg *License:* CC BY-SA 3.0 *Contributors:* Own work *Original artist:* User:Omegatron
- **File:OpAmpTransistorLevel_Colored_Labeled.svg** *Source:* http://upload.wikimedia.org/wikipedia/commons/e/e0/OpAmpTransistorLevel_Colored_Labeled.svg *License:* CC BY 2.5 *Contributors:* redrawn png file (from User:Omegatron), datasheet *Original artist:* Daniel Braun
- **File:Operational_amplifier_noninverting.svg** *Source:* http://upload.wikimedia.org/wikipedia/commons/6/66/Operational_amplifier_noninverting.svg *License:* CC BY-SA 3.0 *Contributors:* my drawing *Original artist:* Ong saluri

- **File:PCB_Carbon_Printed_Resistor.jpg** *Source:* http://upload.wikimedia.org/wikipedia/commons/8/83/PCB_Carbon_Printed_Resistor.jpg *License:* CC BY-SA 3.0 *Contributors:* Own work *Original artist:* Altzone
- **File:Parallel_capacitor_button.svg** *Source:* http://upload.wikimedia.org/wikipedia/en/8/86/Parallel_capacitor_button.svg *License:* CC-BY-SA-3.0 *Contributors:*
Self created using Inkscape
Original artist:
SpinningSpark
- **File:Parallel_inductor_button.svg** *Source:* http://upload.wikimedia.org/wikipedia/en/3/3f/Parallel_inductor_button.svg *License:* CC-BY-SA-3.0 *Contributors:*
Self created using Inkscape
Original artist:
SpinningSpark
- **File:Parallel_resistor_button.svg** *Source:* http://upload.wikimedia.org/wikipedia/en/5/51/Parallel_resistor_button.svg *License:* CC-BY-SA-3.0 *Contributors:*
Self created using Inkscape
Original artist:
SpinningSpark
- **File:Photo-SMDcapacitors.jpg** *Source:* <http://upload.wikimedia.org/wikipedia/commons/8/86/Photo-SMDcapacitors.jpg> *License:* Public domain *Contributors:* ? *Original artist:* ?
- **File:Photo-SMDchips.jpg** *Source:* <http://upload.wikimedia.org/wikipedia/commons/3/30/Photo-SMDchips.jpg> *License:* Public domain *Contributors:* ? *Original artist:* ?
- **File:Preferred_values_05_Pengo.svg** *Source:* http://upload.wikimedia.org/wikipedia/commons/9/91/Preferred_values_05_Pengo.svg *License:* CC BY-SA 3.0 *Contributors:* ? *Original artist:* ?
- **File:Question_book-new.svg** *Source:* http://upload.wikimedia.org/wikipedia/en/9/99/Question_book-new.svg *License:* Cc-by-sa-3.0 *Contributors:*
Created from scratch in Adobe Illustrator. Based on Image:Question book.png created by User:Equazcion *Original artist:* Tkgd2007
- **File:Reactance_button.svg** *Source:* http://upload.wikimedia.org/wikipedia/en/5/5d/Reactance_button.svg *License:* CC-BY-SA-3.0 *Contributors:*
Self created using Inkscape
Original artist:
SpinningSpark
- **File:ResistanceHydraulicAnalogy2.svg** *Source:* <http://upload.wikimedia.org/wikipedia/commons/1/19/ResistanceHydraulicAnalogy2.svg> *License:* CC0 *Contributors:* Own work *Original artist:* Sbyrnes321
- **File:Resistor.jpg** *Source:* <http://upload.wikimedia.org/wikipedia/commons/e/e6/Resistor.jpg> *License:* CC BY-SA 3.0 *Contributors:* Own work *Original artist:* Nunikasi
- **File:ResistorColorCodeGuide.jpg** *Source:* <http://upload.wikimedia.org/wikipedia/commons/e/ec/ResistorColorCodeGuide.jpg> *License:* CC BY-SA 3.0 *Contributors:* Own work *Original artist:* Michael L. Umbrecht
- **File:Resistor_bands.svg** *Source:* http://upload.wikimedia.org/wikipedia/commons/b/b7/Resistor_bands.svg *License:* BSD *Contributors:* *Original artist:* User:Dysprosia, traced by User:Stannered
- **File:Resistor_button.svg** *Source:* http://upload.wikimedia.org/wikipedia/en/6/6a/Resistor_button.svg *License:* CC-BY-SA-3.0 *Contributors:*
Self created using Inkscape
Original artist:
SpinningSpark
- **File:Resistor_cropped.jpg** *Source:* http://upload.wikimedia.org/wikipedia/commons/3/3e/Resistor_cropped.jpg *License:* CC-BY-SA-3.0 *Contributors:* Copy of Image:Resistor.JPG (GFDL), cropped and mirrored. *Original artist:* Maksim / Erik Baas
- **File:Resistors.svg** *Source:* <http://upload.wikimedia.org/wikipedia/commons/2/25/Resistors.svg> *License:* Public domain *Contributors:* Original work *Original artist:* Justin Force
- **File:Resistors_color_code.jpg** *Source:* http://upload.wikimedia.org/wikipedia/commons/b/b9/Resistors_color_code.jpg *License:* CC BY-SA 3.0 *Contributors:* ? *Original artist:* ?
- **File:Resistors_in_parallel.svg** *Source:* http://upload.wikimedia.org/wikipedia/commons/0/09/Resistors_in_parallel.svg *License:* CC BY-SA 3.0 *Contributors:* This SVG electrical schematic was created with the Electrical Symbols Library. *Original artist:* Omegatron0
- **File:Resistors_in_series.svg** *Source:* http://upload.wikimedia.org/wikipedia/commons/1/11/Resistors_in_series.svg *License:* CC BY-SA 3.0 *Contributors:* This SVG electrical schematic was created with the Electrical Symbols Library. *Original artist:* Omegatron0
- **File:Resistors_on_tape.jpg** *Source:* http://upload.wikimedia.org/wikipedia/commons/b/b1/Resistors_on_tape.jpg *License:* Public domain *Contributors:* Own work *Original artist:* Inductiveload
- **File:S-parameter_button.svg** *Source:* http://upload.wikimedia.org/wikipedia/en/0/06/S-parameter_button.svg *License:* CC-BY-SA-3.0 *Contributors:*
Self created using Inkscape
Original artist:
SpinningSpark

- **File:SMD_capacitor.jpg** *Source:* http://upload.wikimedia.org/wikipedia/commons/4/49/SMD_capacitor.jpg *License:* CC BY-SA 3.0 *Contributors:* Own work *Original artist:* Alex Khimich
- **File:SMT_sizes_based_on_original_by_Zureks.svg** *Source:* http://upload.wikimedia.org/wikipedia/commons/3/34/SMT_sizes%2C_based_on_original_by_Zureks.svg *License:* CC BY-SA 3.0 *Contributors:* Own work *Original artist:* Zerodamage
- **File:Series_capacitor_button.svg** *Source:* http://upload.wikimedia.org/wikipedia/en/2/2b/Series_capacitor_button.svg *License:* CC-BY-SA-3.0 *Contributors:*
Self created using Inkscape
Original artist:
SpinningSpark
- **File:Series_inductor_button.svg** *Source:* http://upload.wikimedia.org/wikipedia/en/c/c3/Series_inductor_button.svg *License:* CC-BY-SA-3.0 *Contributors:*
Self created using Inkscape
Original artist:
SpinningSpark
- **File:Series_resistor_button.svg** *Source:* http://upload.wikimedia.org/wikipedia/en/b/b0/Series_resistor_button.svg *License:* CC-BY-SA-3.0 *Contributors:*
Self created using Inkscape
Original artist:
SpinningSpark
- **File:Sil_resistor.png** *Source:* http://upload.wikimedia.org/wikipedia/en/e/e9/Sil_resistor.png *License:* PD *Contributors:*
I (Nkendrick (talk)) created this work entirely by myself. *Original artist:*
Nkendrick (talk)
- **File:Smt_closeup.jpg** *Source:* http://upload.wikimedia.org/wikipedia/commons/6/6b/Smt_closeup.jpg *License:* CC-BY-SA-3.0 *Contributors:* en:Image:Smt_closeup.jpg *Original artist:* en>User:John Fader
- **File:Soldering_a_0805.jpg** *Source:* http://upload.wikimedia.org/wikipedia/commons/f/f8/Soldering_a_0805.jpg *License:* CC BY-SA 3.0 *Contributors:* Own work *Original artist:* Aisart
- **File:Soucetransform.svg** *Source:* <http://upload.wikimedia.org/wikipedia/commons/f/f0/Soucetransform.svg> *License:* Public domain *Contributors:* en:Image:Soucetransform.PNG *Original artist:* Traced by User:Stannered
- **File:Star-polygon_button.svg** *Source:* http://upload.wikimedia.org/wikipedia/en/1/13/Star-polygon_button.svg *License:* CC-BY-SA-3.0 *Contributors:*
Self created using Inkscape
Original artist:
SpinningSpark
- **File:Superposition_button.svg** *Source:* http://upload.wikimedia.org/wikipedia/en/0/0c/Superposition_button.svg *License:* CC-BY-SA-3.0 *Contributors:*
Self created using Inkscape
Original artist:
SpinningSpark
- **File:Susceptance_button.svg** *Source:* http://upload.wikimedia.org/wikipedia/en/3/38/Susceptance_button.svg *License:* CC-BY-SA-3.0 *Contributors:*
Self created using Inkscape
Original artist:
SpinningSpark
- **File:Tellegen_button.svg** *Source:* http://upload.wikimedia.org/wikipedia/en/3/36/Tellegen_button.svg *License:* CC-BY-SA-3.0 *Contributors:*
Self created using Inkscape
Original artist:
SpinningSpark
- **File:Text_document_with_red_question_mark.svg** *Source:* http://upload.wikimedia.org/wikipedia/commons/a/a4/Text_document_with_red_question_mark.svg *License:* Public domain *Contributors:* Created by bdesham with Inkscape; based upon Text-x-generic.svg from the Tango project. *Original artist:* Benjamin D. Esham (bdesham)
- **File:Thevenin_button.svg** *Source:* http://upload.wikimedia.org/wikipedia/en/0/02/Thevenin_button.svg *License:* CC-BY-SA-3.0 *Contributors:*
Self created using Inkscape
Original artist:
SpinningSpark
- **File:Types_of_winding_by_Zureks.png** *Source:* http://upload.wikimedia.org/wikipedia/commons/3/30/Types_of_winding_by_Zureks.png *License:* Public domain *Contributors:* Own work *Original artist:* Zureks
- **File:Ua741_opamp.jpg** *Source:* http://upload.wikimedia.org/wikipedia/commons/4/43/Ua741_opamp.jpg *License:* CC BY 3.0 *Contributors:* Transferred from en.wikipedia; transferred to Commons by User:BokicaK using CommonsHelper. *Original artist:* Teravolt (talk). Original uploader was Teravolt at en.wikipedia

- **File:Voltage_button.svg** *Source:* http://upload.wikimedia.org/wikipedia/en/c/c3/Voltage_button.svg *License:* CC-BY-SA-3.0 *Contributors:*
 Self created using Inkscape
Original artist:
 SpinningSpark
- **File:Wikibooks-logo-en-noslogan.svg** *Source:* <http://upload.wikimedia.org/wikipedia/commons/d/df/Wikibooks-logo-en-noslogan.svg> *License:* CC BY-SA 3.0 *Contributors:* Own work *Original artist:* User:Bastique, User:Ramac et al.
- **File:Wikiversity-logo.svg** *Source:* <http://upload.wikimedia.org/wikipedia/commons/9/91/Wikiversity-logo.svg> *License:* CC BY-SA 3.0 *Contributors:* Snorky (optimized and cleaned up by verdy_p) *Original artist:* Snorky (optimized and cleaned up by verdy_p)
- **File:Wiktionary-logo-en.svg** *Source:* <http://upload.wikimedia.org/wikipedia/commons/f/f8/Wiktionary-logo-en.svg> *License:* Public domain *Contributors:* Vector version of Image:Wiktionary-logo-en.png. *Original artist:* Vectorized by Fvasconcellos (talk · contribs), based on original logo tossed together by Brion Vibber
- **File:Y-delta_button.svg** *Source:* http://upload.wikimedia.org/wikipedia/en/3/39/Y-delta_button.svg *License:* CC-BY-SA-3.0 *Contributors:*
 Self created using Inkscape
Original artist:
 SpinningSpark
- **File:Y-parameter_button.svg** *Source:* http://upload.wikimedia.org/wikipedia/en/a/a5/Y-parameter_button.svg *License:* CC-BY-SA-3.0 *Contributors:*
 Self created using Inkscape
Original artist:
 SpinningSpark
- **File:Z-equivalent_two_port.png** *Source:* http://upload.wikimedia.org/wikipedia/commons/a/ac/Z-equivalent_two_port.png *License:* GFDL *Contributors:* Own work *Original artist:* Brews ohare
- **File:Z-parameter_button.svg** *Source:* http://upload.wikimedia.org/wikipedia/en/2/26/Z-parameter_button.svg *License:* CC-BY-SA-3.0 *Contributors:*
 Self created using Inkscape
Original artist:
 SpinningSpark
- **File:Zero_ohm_resistors_cropped.jpg** *Source:* http://upload.wikimedia.org/wikipedia/commons/0/05/Zero_ohm_resistors_cropped.jpg *License:* Public domain *Contributors:* Photographed by User:Mike1024 *Original artist:* User Mike1024 on en.wikipedia

7.13.3 Content license

- Creative Commons Attribution-Share Alike 3.0